

MACO FLATSIDER 6 PACKING LIST

<u>PART</u>	<u>QTY</u>	<u>OD</u>	<u>SIZE</u>	<u>LGTH</u>	<u>DESCRIPTION</u>	<u>CHECKLIST</u>
T52P	2	2"	.050"	80"	aluminum tubing slotted one end	_____
T31P	2	2"	.050"	80"	aluminum tubing slotted one end & swaged one end	_____
T53	1	1.845"	.060"	80"	aluminum tubing	_____
T11P	7	5/8"	.050"	72"	aluminum tubing slotted both ends	_____
T57P	2	2"	.050"	36"	aluminum tubing swaged one end to 1.875"	_____
T01	10	1/2"	.050"	72"	aluminum tubing	_____
WD2P	1		6/18	25'	steel guy cable	_____
V03P	1		1"x1"	24'	vertical guy support	_____
P03P	1		1/4" x 6"	8"	2" boom to 2" mast plate	_____
W05P			7/14	90'	stranded copper antenna wire	_____
FA2P	4			48"	multi-screen fiberglass rods	_____
2600	1			5 KW	gamma match	_____
S42	1				coax connector w/plastic washers	_____
Z08P	2				gamma straps for coax connectors	_____
BAG #1						
U01	20		2"		plated u-bolts	_____
N03	40		5/16"		lock nuts	_____
BAG #2						
S01	20		2"		plated saddles	_____
BAG #3						
EG2	4				egg insulators	_____
N18	2		5/16"		eye bolts w/2 NO1 each	_____
PL1	2		3/8"		plastic caps – black	_____
PL2	10		.437"		plastic caps – black	_____
PL5	1		2"		plastic cap - black	_____
PL5R	1		2"		plastic cap – red	_____
Z02P	2				4" gamma straps	_____
N11	19		10-24		square nuts	_____
S21	19		10-24	1/2"	machine screws	_____
W58P	14		5/8"		extruded aluminum clamps	_____
N26	4				No. 10 flat washers	_____
	3				fiberglass rod kit (4 screws)	_____
	1				tip sheet	_____
	1				warranty sheet	_____
	1				instruction sheet	_____
BAG #4						
BE2P	7				2" boom to 5/8" element mounts	_____

WHEN ORDERING PARTS, ALWAYS GIVE PART NUMBER AND DESCRIPTION.

Please note: In an effort to keep the price on Maco Antennas down, we have decided not to clean up all the burrs and rough edges on the parts. We recommend that you deburr and clean up each part with files, sandpaper, etc. so that they go together easily. We are aware this needs to be done but have elected not to do it to save you the money we would have to add to the price of the kit for this service.

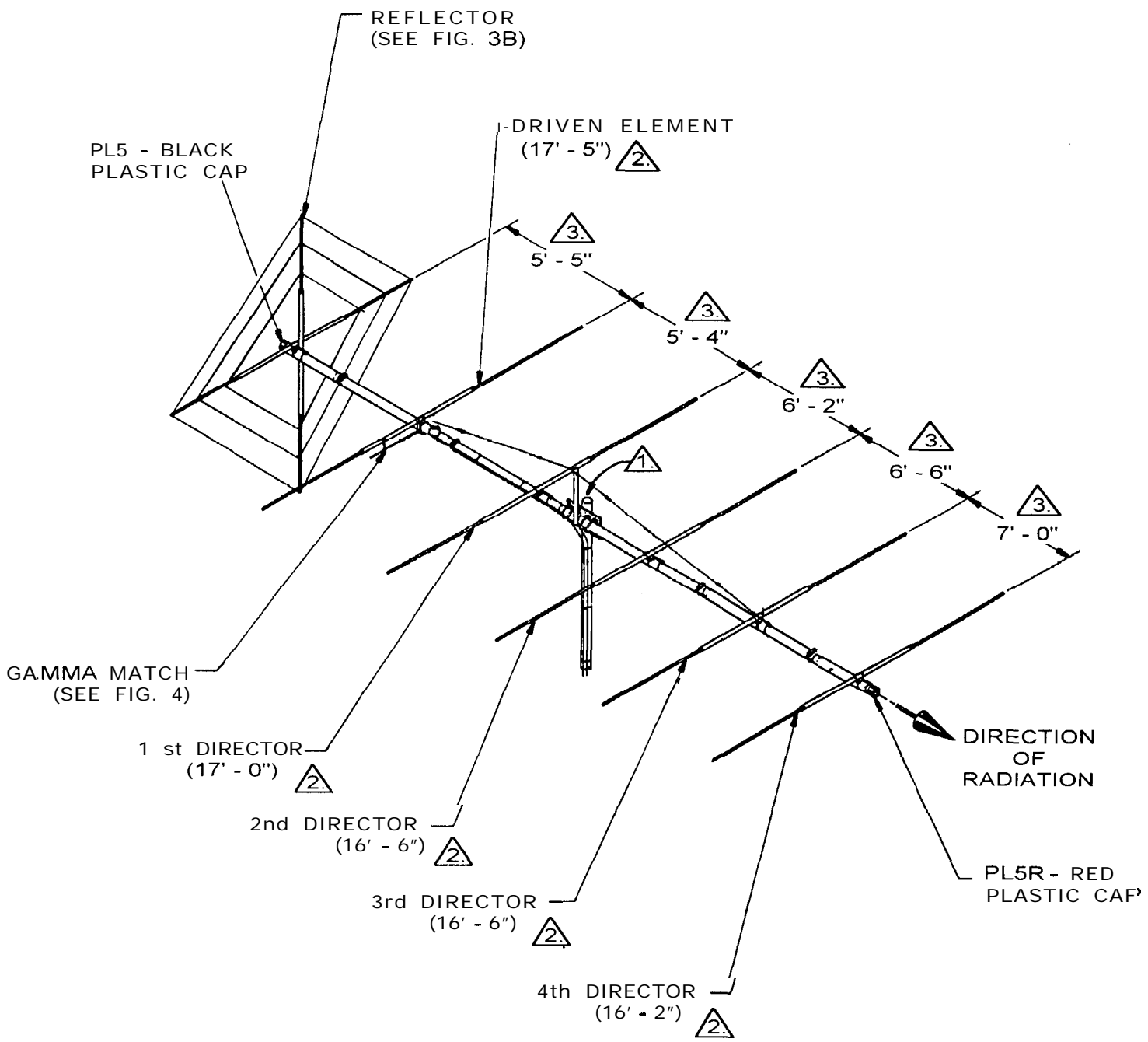

NOTES:
 ▲ FOR DETAILS OF BOOM & GUY ASSEMBLY AND MAST MOUNTING, SEE FIG. 2.
 ▲ FOR DETAILS OF ELEMENT ASSEMBLY AND MOUNTING, SEE FIG. 3.

GENERAL ASSEMBLY FIGURE 1

MACO FLATSIDER 6

ASSEMBLY INSTRUCTIONS

FIGURE 1 GENERAL INSTRUCTIONS

This drawing depicts an overall view of what the antenna should look like upon completion of assembly. Refer to Figures 2 thru 4 for specific assembly details. All hardware should be coated with a silicon rubber sealant or similar compound to insure that wind vibration does not cause it to work loose.

Upon completion of assembly, install the red plastic cap (PL5R) on the director end of the antenna, and the black cap (PL5) on the reflector end. This will allow you to determine at a glance the direction of transmit and receive.

FIGURE 2 BOOM & GUY ASSEMBLY

To assemble the boom, first mark the center of the boom coupler (T53) and slide the unslotted ends of the center boom sections (T52P) over the each end of the coupler so that they butt in the center. Next attach the boom-to-mast plate (P01P) and the vertical guy support (V03P) at the boom center using 2" U-bolts, saddles and hardware as shown. (Refer to Detail 2A.)

Now, slide the **swaged** ends of the intermediate boom sections (T3 1P) into the slotted ends of the center boom sections. Secure with 2" U-bolts, saddle and hardware as shown. (Refer to Detail 2B.) Next, slide the **swaged** ends of the boom sections and secure in the same manner. (Refer to Detail 2B.)

The first step in assembling the guy cable is to cut four lengths of 2 feet each off the roll of cable. Take two 2 foot lengths and attach one end of each to an egg insulator (EG1) and the other end to an **eyebolt** (N18) so that the distance between the **eyebolt** and the insulator is 1 foot. Attach both **eyebolts** to the vertical guy support with 5/16" **hexnuts** as shown in detail 2C. Run the outside hex nuts only a couple of turns onto the ends of the **eyebolts** and leave the inside nuts loose so that you can take the slack out of the cable later. Now take two 2 foot lengths and attach an egg insulator to one end of each in the same manner. (At this point, it is necessary to go on to element assembly and mounting, before completing the guy cable assembly.)

Take both 2 foot cable lengths with the egg insulators attached and fasten one to the boom and the driven element and the other at the 3rd director. Wrap as shown in Detail 2D so that the distance between the boom and insulator is 1 ft.

Now take the remaining cable and allowing approximately 9" at each end for wrapping, stretch it between the insulators one end of the boom and cut it off. Leaving as little slack as possible, wrap each end of the cable around the insulators as shown in details 2C and 2D.

Do the same thing for the cable on the other end of the boom. Take the rest of the slack out of the cables by tightening the outside hex nuts on the eyebolts. Lock them in place by tightening the inside hex nuts. This antenna is designed for mounting on a 2" O.D. heavy duty mast. Mount using 2" U-bolts, saddles and hardware as shown in Detail 2E.

FIGURE 3 ELEMENT ASSEMBLY

Prior to assembling elements slide a boom-to-element mount (BE2P) onto each of the (6) element center sections (TI1P). Assemble each element as shown using the clamps and hardware specified. Refer to the element table to determine dimensions for each element. Install a black plastic cap (PL2) onto both ends of each element. Assemble the reflector elements in the same manner, sliding the fiberglass arms approximately 6 inches into the ends of the center sections (TI1P). Snug the clamps but don't tighten at this time because the arms will have to be adjusted after installing the reflector wire.

FIGURE 3B ELEMENT MOUNTING

Mark each element at the center and be sure that the boom-to-element mounts (**BE2P**) are centered on the elements before tightening hardware. Starting 1" from the director end of the boom, mount each element using 2" U-bolts, saddles, boom-to-element mounts and hardware as shown. Refer to Figures 1 & 3B for element spacing dimensions. (At this point go back and complete the guy cable assembly.)

FIGURE 3C REFLECTOR ASSEMBLY

The length of the reflector wire is very critical. It must be the correct length to operate correctly. Take the wire (**WO4P**) and uncoil it making sure that there are no kinks; secure it to a nail. Pull the wire until it stretches an inch or so. The easy way to get the correct length for the reflector loop is as follows:

1. Drive 2 nails in a board or fence 1/2 the length of the loop apart --which is 225-1/2" between them.
2. Stretch the wire around the nails by hand as tightly as possible and splice ends together. Solder the splice. Remove one nail and remove the loop. Cut any excess wire off.
3. Loosely assemble the machine screws (**S2 1**), flatwashers (**N26**), lo&washers (**N12**), and hex nuts (**N06**) onto the lugs of the fiberglass arms, adjusting the length as shown.
4. Tighten 3 of the 4 clamps that hold the fiberglass rods.
5. Install the wire as shown.
6. Tighten the wire by pulling the fourth fiberglass rod until the wire is the same tightness as it was around the nails. The wire loop is now the correct length. Note the total length of the loop is critical, and also is the length of each side. REMEMBER: Reflector dimensions are only preliminary. Change to get equal sides of 9' 4-3/4" . Fiberglass length is not critical, however the equal wire length of 9' 4-3/4" is very critical.
7. Take the remaining reflector wire and thread it through the drill holes in the four spreaders pulling stung and splicing each piece. This completes the reflector assembly.

FIGURE 4 GAMMA MATCH MOUNTING

Mount the gamma match (**GO 1P**) to the horizontal driven element, using the gamma strap (**Z02P, Z08P**) and attaching hardware as shown. Attach your 52 ohm coaxial cable to the connector (**S42**) and dress along boom and down the mast.

ADJUSTING STANDING WAVE RATIO

Refer to Figure 4. The dimensions given are approximate and should be used as a starting point. The following instructions cover the adjustment of one gamma match. To adjust the second gamma match, simply repeat this procedure.

The gamma match has 2 adjustments. First is the capacitor adjust and the second is the slider adjust. Connect a S.W.R bridge to the coax between your transmitter and the antenna and check the S.W.R. If adjustment is required loosen the clamp on the gamma match and the screws holding the slider (Gamma Straps **Z02P**). Next move the capacitor adjustment first in one direction then the other until a minimum S.W.R. reading is obtained. If S.W.R. is not yet satisfactory, move the slider out 2" away from the boom. **If the** reading has gone up, move the slider back to the original position and then 2" toward the boom. Now readjust the capacitor for minimum S.W.R. you should now be able to determine which direction to move the slider. Repeat the above procedure moving the slider in smaller increments until a satisfactory S.W.R. reading is obtained. Tighten all hardware. Disconnect the S.W.R. bridge and reconnect your coaxial cable.

the screws. Bring the ends together and lineup the marks that are 2" from each end. Now twist the loose ends together and solder as shown. Adjust each fiberglass arm so that the reflector wire becomes taut and each leg of the square is 9' -4 3/4" and tighten the clamps. A slight natural bowing of the fiberglass is normal. This will not affect normal operation of the antenna as long as the lengths of wire are correct.

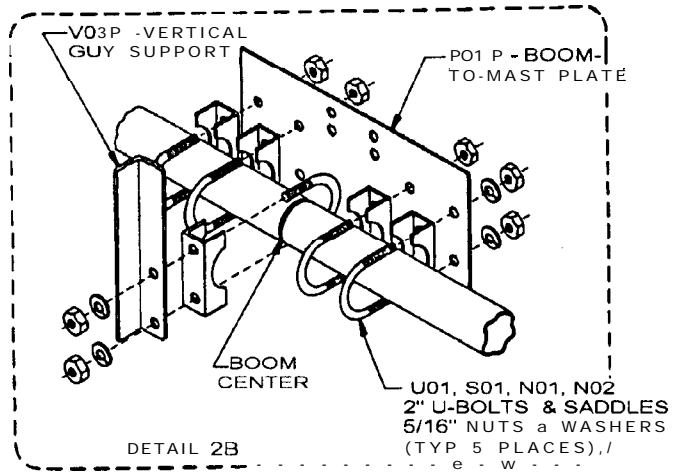
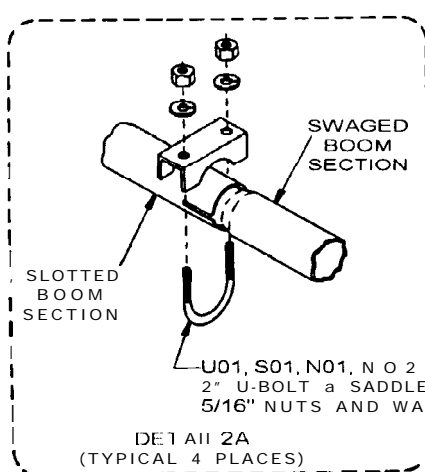

***NOTE:**
 HORIZONTAL ELEMENTS ONLY ARE SHOWN FOR REFERENCE.
 SEE FIGURE 3B FOR ELEMENT MOUNTING DETAILS.

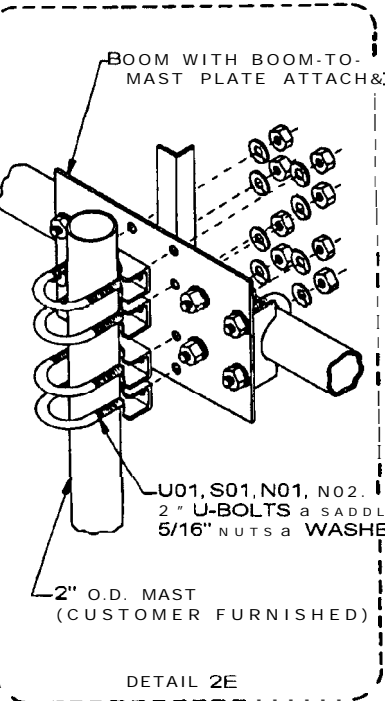
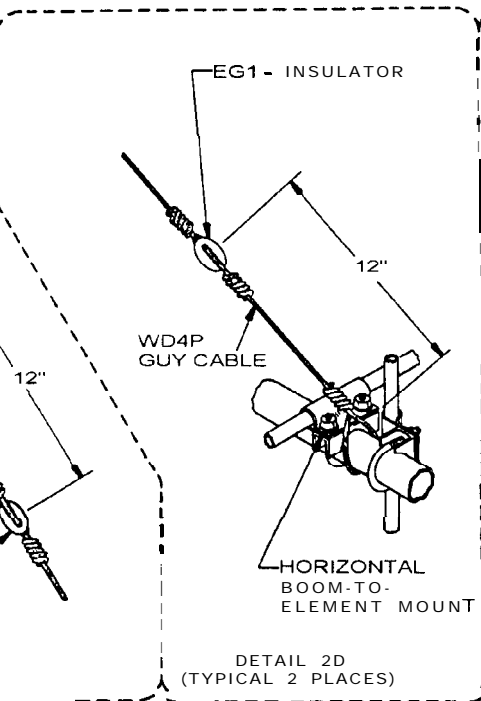
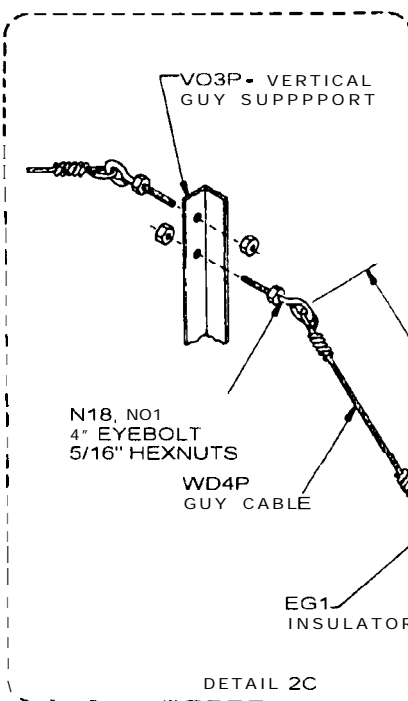
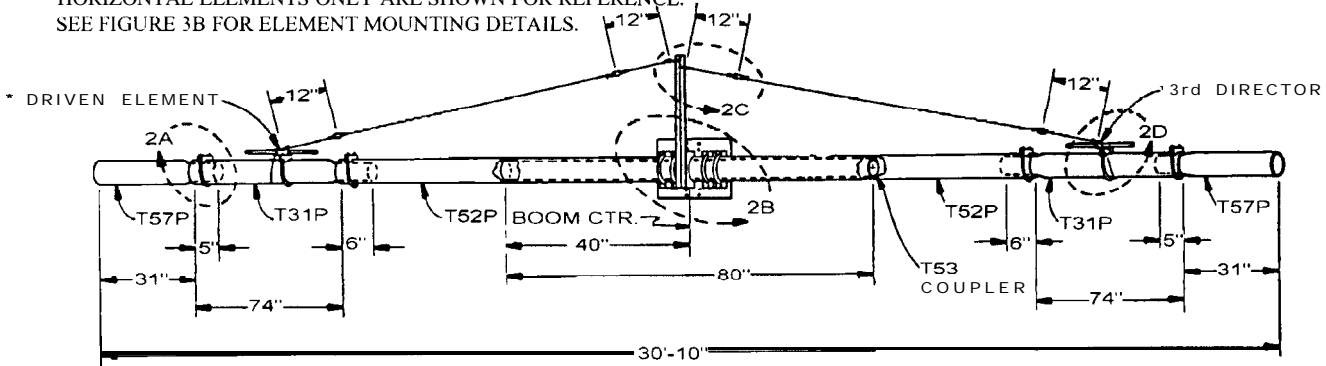
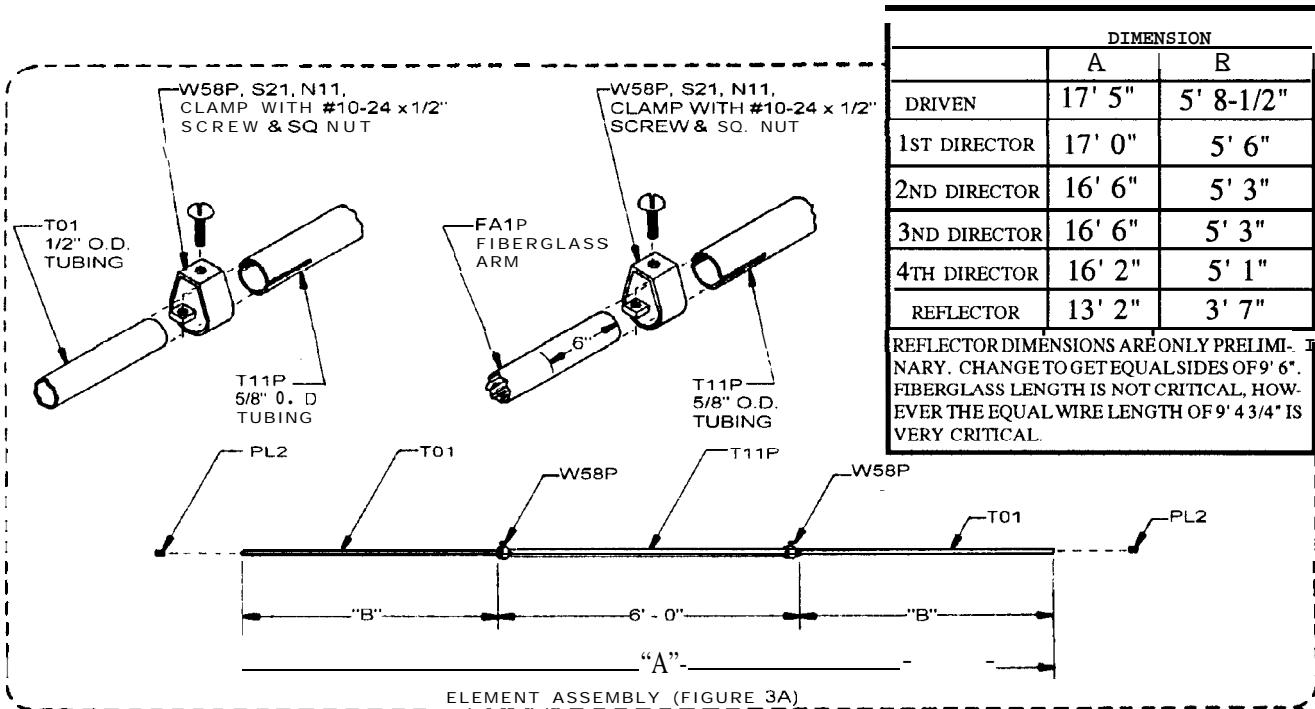
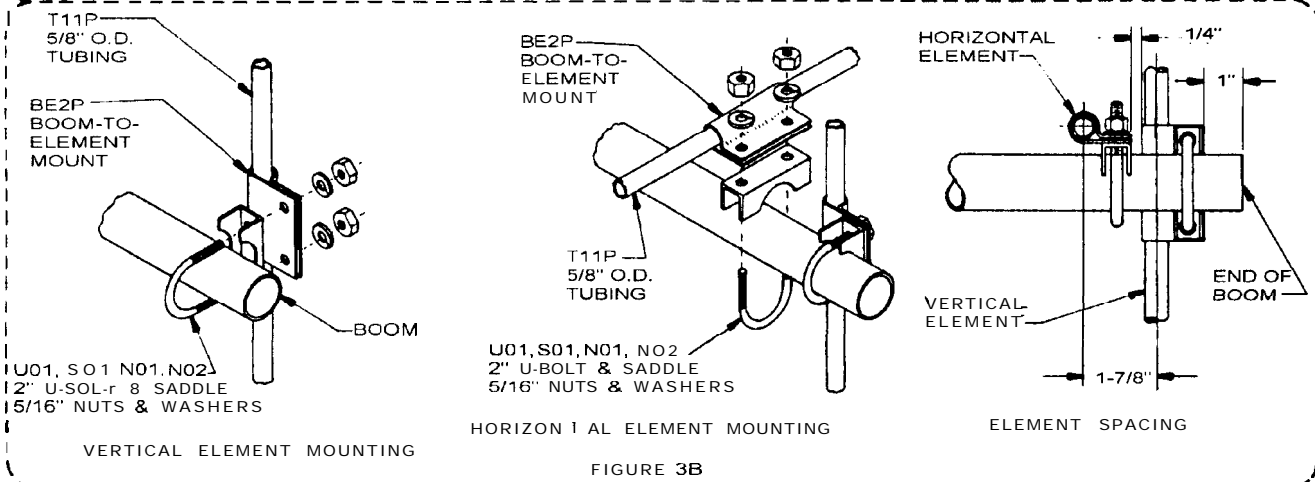

FIGURE 2



	DIMENSION	
	A	B
DRIVEN	17' 5"	5' 8-1/2"
1ST DIRECTOR	17' 0"	5' 6"
2ND DIRECTOR	16' 6"	5' 3"
3ND DIRECTOR	16' 6"	5' 3"
4TH DIRECTOR	16' 2"	5' 1"
REFLECTOR	13' 2"	3' 7"

REFLECTOR DIMENSIONS ARE ONLY PRELIMINARY. CHANGE TO GET EQUAL SIDES OF 9' 6". FIBERGLASS LENGTH IS NOT CRITICAL, HOWEVER THE EQUAL WIRE LENGTH OF 9' 4 3/4" IS VERY CRITICAL.



Please read the Assembly and Troubleshooting Tips at the end of this instruction booklet before assembling elements.

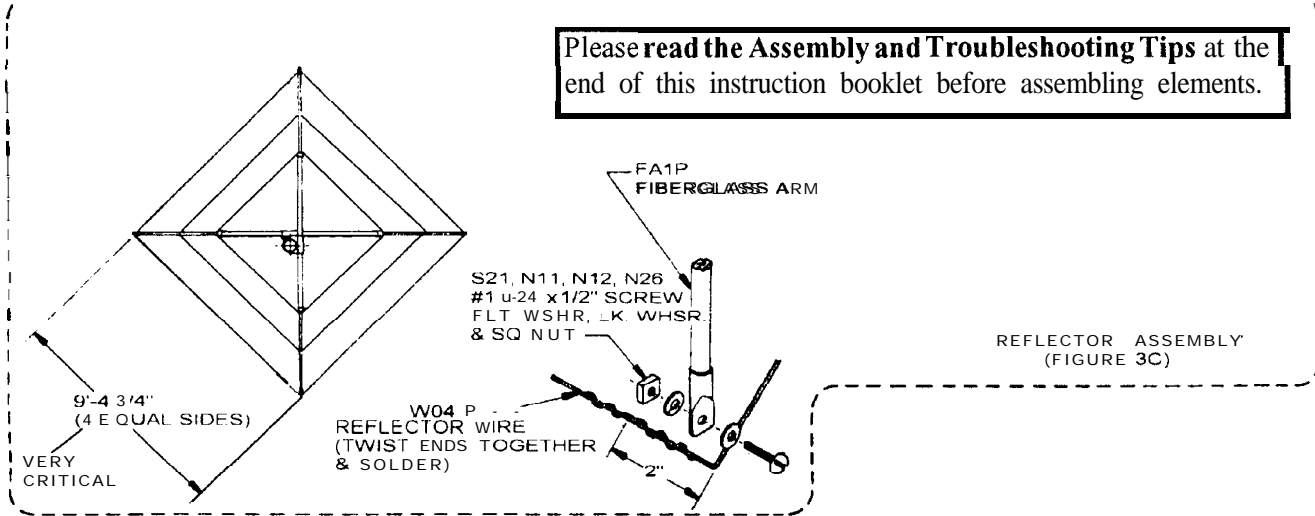

ELEMENT ASSEMBLY & MOUNTING
FLATSIDER 6

FIGURE 3

* NOTE: THESE DIMENSIONS ARE APPROXIMATE. REFER TO THE INSTRUCTIONS ON ADJUSTING THE S.W.R. TO DETERMINE EXACT SETTINGS. THERE ARE 2 SEPARATE GAMMA ADJUSTMENTS, 1. CAPACITOR ADJUSTMENT, 2. SLIDER POSITION.

DO NOT MOVE BOTH AT THE SAME TIME. MOVE THE CAPACITOR FIRST, THEN, IF NECESSARY MOVE THE SLIDER, AND GO BACK TO THE CAPACITOR.

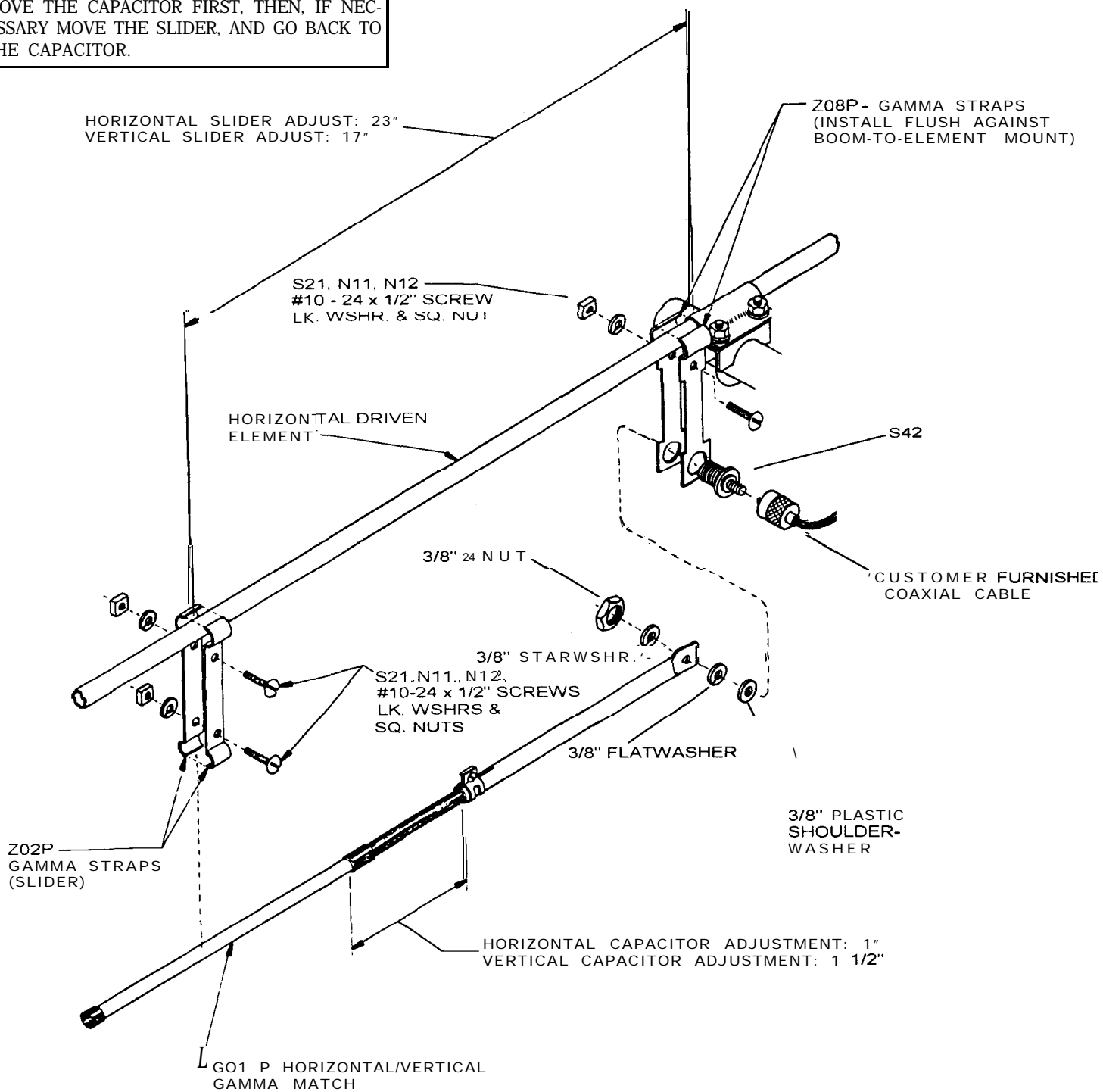

GAMMA MATCH MOUNTING

FIGURE 4

DANGER

**High Voltage
Overhead**



Caution:

**TAKE CARE TO AVOID ANY CONTACT WITH
OVERHEAD POWERLINES WHEN RAISING,
INSTALLING, OR REPAIRING YOUR
ANTENNA, TOWER, OR ROTOR.**

DEATH WILL OCCUR!

Installing and rigging towers, masts and antennas require specialized skills and experience. Information supplied by MACo assumes that all products will be installed by personnel having these skills and have installed similar products before. No one should attempt to install towers or masts without these knowledgeable skills.

MACo assumes no liability if faulty or dangerous installation practices are used. There are available, trained and experienced personnel to assist in installation, maintenance, or disassembly. Contact your local installer if consultation or assistance is required.

All tower and antenna installations should be thoroughly inspected at least twice a year by qualified, experienced, and trained personnel to insure proper performance and safety standards.

Electrical Warning

An additional warning precaution is given to be careful of surrounding high voltage power wires and other electrical hazards during installation of your tower, rotor, or antenna.

Do not erect a tower, rotor, or antenna during an electrical storm, rainstorm, or when lightning is a possibility.

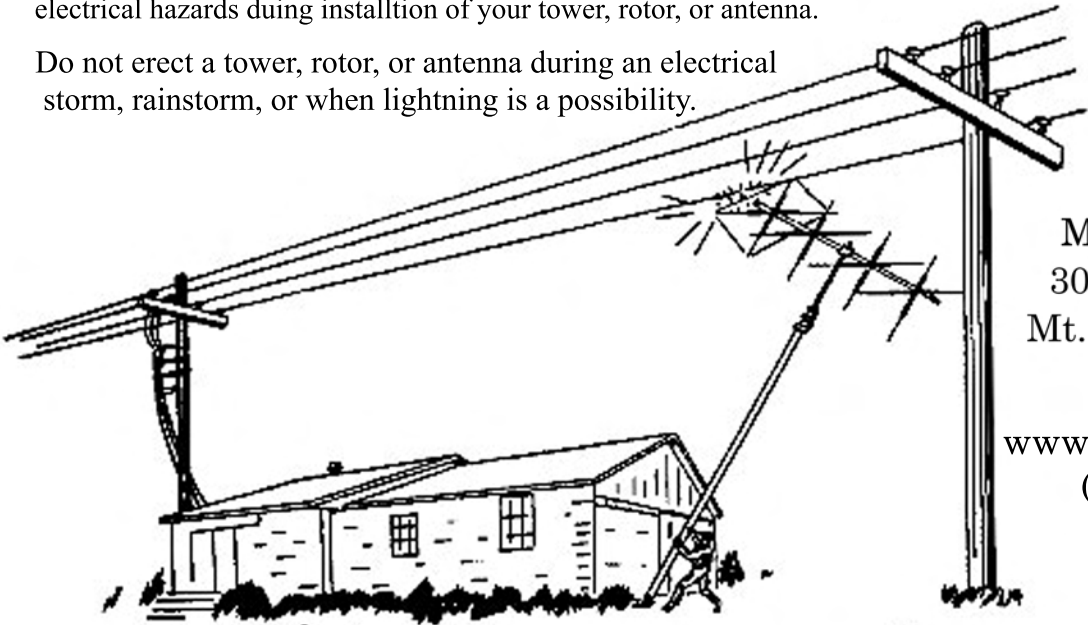

MACo Antennas
302 S. East Street
Mt. Carroll, IL 61053

www.macoantennas.net
(815) 244-3500