

IOTA

ENGINEERING, L.L.C.

P.O. BOX 11846 TUCSON, AZ 85734
 (520) 294-3292 • FAX (520) 741-2837
www.iotaengineering.com

IOTA POWER CONVERTER/CHARGER OWNER'S MANUAL

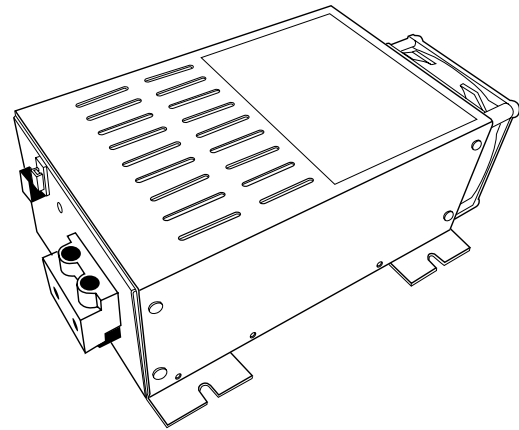

The IOTA Power Converter/Battery Charger converts 120 volts nominal A.C. to 13.6 volts D.C. As a power supply, its tightly controlled regulation allows the user to operate any 12 volt nominal D.C. load up to the converter's rated output current. As a battery charger, the converter will maintain the battery, delivering its full-rated current when the battery capacity falls sufficiently low. The voltage is set to deliver its maximum current for the necessary period of time that minimizes undue stress to the battery caused by heating of its cells. This helps to ensure the longest possible life of the battery. Over time, as the battery nears its full capacity, the converter will float-charge the battery to prevent self-discharge of its cells.

PROTECTION FEATURES

The IOTA Power Converters/Battery Chargers are designed with high quality components to help ensure years of continuous use. The unit is protected by multiple protection features for a long, trouble-free life.

1) *Reverse Battery Polarity Protection.* 2) *Brown-Out Input Protection.* 3) *Over-Current Protection* - cycle by cycle peak limiting as well as rated current limiting to maximize the life of the converter. 4) *Over-Temperature Protection.* In addition, it is designed with a unique "proportional" fan control circuit. Fan speed is directly proportional to the converter's internal ambient temperature. This enables the fan to turn on and off very slowly, minimizing unwanted fan-starting noise.

WARRANTY

The IOTA Power Converters/Battery Chargers are warranted from defects in materials or workmanship for two years from date of retail purchase, and limits the remedies to repair or replacement. This warranty is valid only in the continental United States and Canada. For complete warranty details, contact Customer Service or visit www.iotaengineering.com.

| MODEL | DLS 15 SERIES M | DLS 30 SERIES M | DLS 45 SERIES M | DLS 55 SERIES M | DLS 75 | DLS 90 |
|--------------------|----------------------------------|-----------------------|-----------------------|-----------------------|----------------|----------------|
| INPUT VOLTS (Vac) | 108-132 | 108-132 | 108-132 | 108-132 | 108-132 | 108-132 |
| FREQUENCY (Hz) | 47-63 | 47-63 | 47-63 | 47-63 | 47-63 | 47-63 |
| MAX AMP DRAW (AC) | 3.5 | 7 | 11 | 13 | 17 | 21 |
| MAX WATT DRAW (VA) | 250 (390) | 500 (770) | 750 (1160) | 950 (1460) | 1300 (2000) | 1500 (2300) |
| OUTPUT AMPS (DC) | 15 | 30 | 45 | 55 | 75 | 90 |
| OUTPUT VOLTS (DC) | 13.6 NOMINAL 13.4 @ FULL LOAD | | | | | |
| DIMENSIONS* | | | | | | |
| WIDTH | 9.7" | 9.7" | 9.7" | 9.7" | 6.5" | 6.5" |
| LENGTH | 6.7" | 6.7" | 6.7" | 6.7" | 10" | 10" |
| HEIGHT | 3.4" | 3.4" | 3.4" | 3.4" | 3.5" | 3.5" |

*DETAILED MOUNTING SPECIFICATIONS ARE AVAILABLE ONLINE AT WWW.IOTAENGINEERING.COM

Distributed By:

INSTALLATION GUIDELINES

There are no components within the IOTA Power Converters/Battery Chargers that, in their normal operation, produce arcs or sparks. However, all electronic devices have some potential for generating sparks in the event of failure. Therefore, never install this device in the same compartment with flammable items such as gasoline or batteries.

MOUNTING LOCATION

The IOTA Power Converter/Battery Charger can be mounted in any position within an enclosed or interior compartment. Provide sufficient air space to allow unrestricted airflow in and around the unit.

INSTALLATION

Disconnect the positive side of the battery before installation. Connect the positive (red) and negative (black) terminal lugs to battery or load. Always use the proper size wire based on the amperage of the converter and the battery. When connecting to a battery, a breaker should be installed within 18" of the battery, connecting the battery positive to the line side of the breaker, and the IOTA unit to the load side. Connect "Chassis Bonding Lug" on the IOTA unit to vehicle chassis or other grounding source.

DLS MODEL*

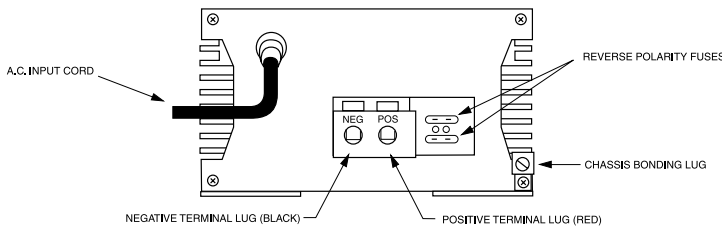

120 VOLT A.C. INPUT

Plug the unit A.C. input cord into a 120 volt 3 wire grounded source. See chart for maximum current draw and required input voltages.

REVERSE POLARITY FUSES

The IOTA Battery Charger/Power Supply is protected against reverse polarity on the DC output. If a battery or the unit is hooked up incorrectly, the fuses will blow and can be easily replaced. Always use the same size and style fuse that came with the converter. To change the fuses, use a screwdriver to loosen the screws and remove the fuses. Always replace the fuses with the same type and rating. After inserting the new fuses, tighten the screws firmly. Apply 5 inch-pound maximum torque. DO NOT OVERTIGHTEN.

DLS SERIES M MODEL*

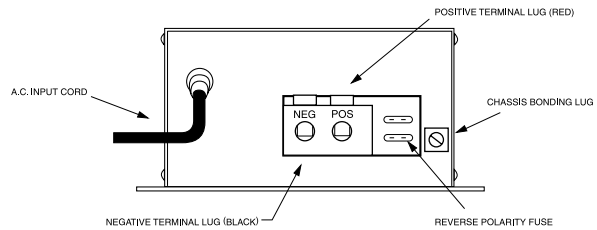

*Actual component locations may vary depending on model.

CHARGE CONTROL

TWO-STEP VOLTAGE JACK

The two-step voltage jack allows switching from a long-term float voltage of 13.6vdc up to 14.2vdc. When the included dual voltage plug is inserted in the jack*, the voltage rises to 14.2vdc for occasional fast charging. When the plug is removed, the voltage drops to 13.6vdc to reduce battery water loss. **WARNING: To avoid battery damage, remove the Dual Voltage Plug when quick-charging is complete.** NOTE: If the unit is equipped with an internal IQ4 smart charger, two-step charging is not needed and the Dual Voltage Jack is disabled.

*Location of the Dual Voltage Jack may vary depending on model.

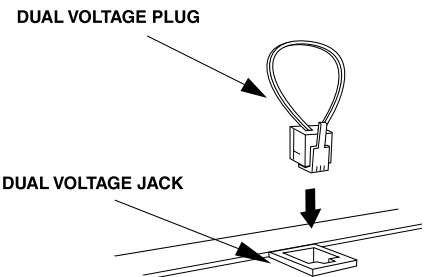

THE IQ4 LED INDICATOR

(ONLY ON IOTA MODELS WITH INTERNAL IQ4)

IOTA Models with an internal IQ4 smart-charger give the user the benefit of automatic Bulk, Absorption, and Float stage charging. This increases the charging capacity of the IOTA charger, decreases charge times and insures proper and safe battery charging without over-charging. The green LED on the fan end of the unit will indicate which charging phase the IOTA unit is currently in. When the unit is first activated, the LED will flash as it reads the number of cells in the battery. The unit will then proceed directly to the Bulk charging or Float charging phase depending on the charge status of the battery. Use the LED CODE TABLE for reference when checking the LED. Units that do not have an internal IQ4 smart-charger can easily install an external IQ4 that plugs into the available Dual Voltage Jack. Contact Customer Service for more information.

LED CODE TABLE

| CELL INDICATION | | |
|-----------------|------------------------|---------------|
| 6 FLASHES | 12V Battery (6 cells) | |
| 12 FLASHES | 24V Battery (12 cells) | |
| 18 FLASHES | 36V Battery (18 cells) | |
| 24 FLASHES | 48V Battery (24 cells) | |
| CHARGE PHASE | LED STATUS | VOLTAGE RATE |
| FLOAT | ON | 2.26 PER CELL |
| ABSORPTION | SLOW FLASHING | 2.36 PER CELL |
| BULK | RAPID FLASHING | 2.46 PER CELL |