

Galaxy

DX-86V

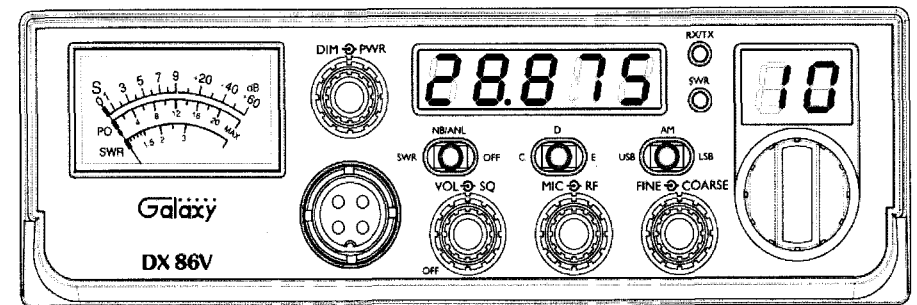

AM/SSB
10 Meter Amateur Mobile Transceiver
With Built in Frequency Counter

OWNER'S MANUAL

TABLE OF CONTENTS

	Page
Specification	2
Installation	
Location	3
Mounting the Radio	3
Ignition Noise Interference	4
Antenna	4
Tuning the Antenna for Optimum SWR	5
External Speaker	6
Operation	
Control Functions	7
A. Front Panel	7
B. Rear Panel	9
Press-To-Talk Microphone	10
Operating Procedure to Receive	10
Operating Procedure to Transmit	10
Alternate Microphones and Installation	11

SPECIFICATIONS

GENERAL

Model	DX-86V
Frequency Range	28.765 ~ 29.205 MHZ
Emission	AM /USB/LSB
Frequency Control	Phase-Lock-loop (PLL) Synthesizer
Frequency Stability	0.001%
Temperature Range	-20°C to +50°C
Antenna Impedance	50 Ohms
Antenna Connectors	Standard SO-239 type
Input Voltage	13.8V DC
Size	7 1/4" (W) x 9" (D) x 2 1/4" (H).
Weight	3.708 lbs.

TRANSMITTER

RF Power Output	AM : 10W SSB : 25W PEP
Spurious Emission	>-50 dB
Audio Distortion	<10%
Frequency Response	300 to 2500 Hz
Microphone	Dynamic

RECEIVER

Sensitivity	AM: 0.5 uV for 10dB Sinad SSB: 0.25Uv for 10dB Sinad
Squelch Sensitivity	< 0.5 uV
Image Rejection	> 50 dB
Audio Power Output	3W @ 10% Distortion
Audio Response	300 to 2500 Hz

(SPECIFICATIONS SUBJECT TO CHANGE WITHOUT NOTICE)

Installation

LOCATION

Plan the location of the transceiver and microphone bracket before starting the installation. Select a location that is convenient for operation and does not interfere with the driver or passengers in the vehicles. In automobiles, the transceiver is usually mounted below the dash panel, with the microphone bracket beside it.

MOUNTING THE RADIO

Your transceiver is supplied with a universal mounting bracket. When mounting the bracket and radio to your car, make sure it is mechanically strong. Also provide a good electrical connection to the chassis of the vehicle. Proceed as follows to mount the transceiver:

1. After you have determined the most convenient location in your vehicle, hold the transceiver with mounting bracket in the exact location desired. If nothing will interfere with mounting it in the desired position, remove the mounting bolts. Before drilling the holes, make sure nothing will interfere with the installation of the mounting bolts.
2. Connect the antenna cable plug to the standard receptacle on the rear panel. Most antennas are terminated with a type PL-259 plug and mate with the receptacle.
3. Connect the red DC power input wire (with the fuse) to +13.8V DC. This wire extends from the rear panel. In automobile installation, +13.8V DC is usually obtained from the accessory contact on the ignition switch. This prevents the set being left on accidentally when the driver leaves the car and also permits operating the unit without the engine running. Locate the accessory contact on most ignition switches by tracing the power wire from the AM broadcast receiver in the car.
4. Connect the black lead to -13.8V DC. This is usually the chassis of the car. Any convenient location with good electrical contact (remove paint) may be used.
5. Mount the microphone bracket on the right side of the transceiver or near the transceiver, using two screws supplied. When mounting in an automobile, place the bracket under the dash so the microphone is readily accessible.

IGNITION NOISE INTERFERENCE

Use of a mobile receiver at low signal levels is normally limited by the presence of electrical noise. The primary source of noise in automobile installations is from the generator and ignition system in the vehicle. Under most operating conditions, when signal level is adequate, the background noise does not present a serious problem. Also, when extremely low level signals are being received, the transceiver may be operated with vehicle engine turned off. The unit requires very little current and therefore will not significantly discharge the vehicle battery.

Even though the transceiver has ANL and NB controls, in some installations ignition interference may be high enough to make good communications impossible. The electrical noise may come from several sources. Many possibilities exist and variations between vehicles require different solutions to reduce the noise.

ANTENNA

A vertically polarized, quarter-wavelength whip antenna provides the most reliable operation and greatest range. Shorter, loaded-type whip antennas are more attractive, compact and adequate for applications where the maximum possible distance is not required. Also, the loaded whips do not present the problems of height imposed by a full quarter-wavelength whip.

Mobile whip antennas utilize the metal body of the vehicle as a ground plane. When mounted at a corner of the vehicle they are slightly directional, in the direction of the body of the vehicle. For all practical purpose, however, the radiation pattern is nondirectional. The slight directional characteristic will be observed only at extreme distance. A standard antenna connector (type SO239) is provided on the transceiver for easy connection to a standard PL 259 cable termination.

If the transceiver is not mounted on a metal surface, it is necessary to run a separate ground wire from the unit to a good metal electrical ground in the vehicle. When installed in a boat, the transceiver will not operate at maximum efficiency without a ground plate, unless the vessel has a steel hull.

Before installing the transceiver in a boat, consult your dealer for information regarding an adequate grounding system and prevention of electrolysis between fittings in the hull and water.

TUNING THE ANTENNA FOR OPTIMUM SWR

Since there is such a wide variety of base and mobile antennas, this section will strictly concern itself to the various types of mobile adjustable antennas.

Because the antenna length is directly related to the channel frequency, it must be tuned to resonate optimally all 40 channels of the transceiver. Channel 1 requires a longer antenna than Channel 40 because it is lower in frequency.

Due to the various methods of adjusting antennas for proper SWR we have chosen what we think is the optimum method:

A. Antennas with adjustment screws (set screws)

1. Start with the antenna extended and tighten the set screw lightly enough so that the antenna can be lightly tapped with your finger for easy adjustment.
2. Set your transceiver to Channel 21. @ band C or band D. Press the PTT (push-to-talk) switch, and tap the antenna (making it shorter). The SWR meter will show a lower reading each time the antenna is tapped. By continuing to shorten the antenna you will notice the SWR reading will reach a low point and then start rising again. This means that you have passed the optimum point for Channel 21. Extend the antenna a short distance and again follow the procedure above.

When the lowest point has been reached, switch to Channel 1 @ band A and then to Channel 40 @ band F and compare SWR readings. They should be almost equal.

B. Antennas which must be cut to proper length.

1. Follow the same procedure as above, but adjust the length by cutting in 1/8" increments until a good match is obtained.
2. *Be very careful not to cut too much at one time, as once it is cut, it can no longer be lengthened.*
3. The whip is easily cut by filing a notch all the way around and breaking the piece off with pliers.

NOTE

THE PROPER SETTING IS ACHIEVED WHEN THE SWR IS 1.5 OR BELOW, AND WHEN IT HAS THE SAME READING FOR CHANNELS BAND A1 AND BAND F40.

If you are having difficulties in adjusting your antenna, check the following:

- A. All doors must be closed when adjusting the antenna.
- B. Make sure the antenna base is grounded.
- C. Check your coaxial cable routing (it may be pinched when routed into the car).
- D. Try a different location on your car (keeping in mind the radiation pattern you wish)
- E. Is the antenna perfectly vertical?
- F. Try a different location in your neighborhood. Stay away from large metal objects when adjusting (metal telephone or light posts, fences, etc.).

NOTE

The transceiver will operate into an SWR of 2 to 1 indefinitely and sustain an SWR of 20:1 for a maximum of 5 minutes at rated operating conditions.

EXTERNAL SPEAKER

The external speaker jack (EXT.SPK) on the rear panel is used for remote receiver monitoring. The external speaker should have 8 ohms impedance and be able to handle at least 4 watts. When the external speaker is plugged in, the internal speaker is disconnected.

Operation

CONTROL FUNCTIONS

There are seventeen controls and five indicators on the front panel of your transceiver.

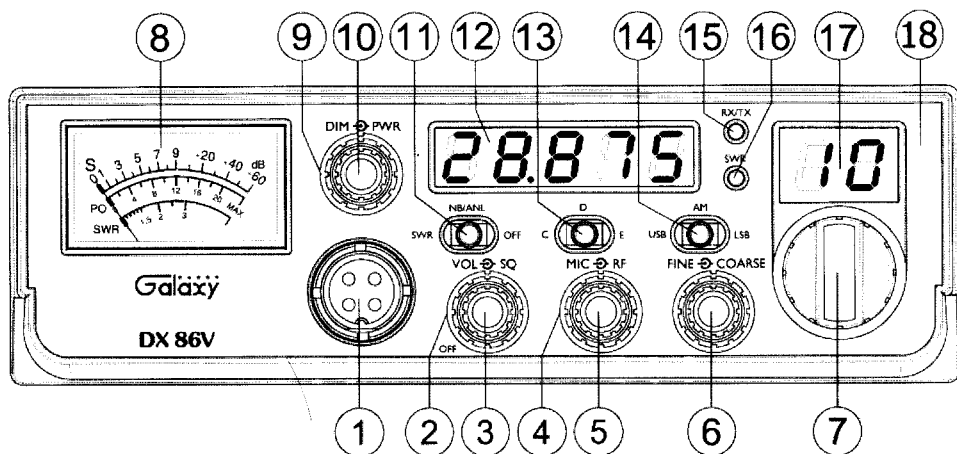

FRONT PANEL

- 1. MICROPHONE JACK:** Used for connecting a microphone for voice source.
- 2. SQUELCH :** This control is used to cut off or eliminate receiver background noise in the absence of an incoming signal. For maximum receiver sensitivity it is desired that the control be adjusted only to the point where the receiver background noise or ambient backgrounds noise is eliminated. Turn fully counterclockwise then slowly clockwise until the receiver noise disappears. Any signal to be received must now be slightly stronger than the average received noise. Further clockwise rotation will increase the threshold level, which a signal must overcome in order to be heard. Only strong signals will be heard at a maximum clockwise setting.
- 3. ON/OFF VOLUME CONTROL:** Turn clockwise to apply power to the unit and to set the desired listening level. During normal operation, the VOLUME control is used to adjust the output level obtained either at the transceiver speaker or the external speaker, if used.
- 4. RF GAIN CONTROL:** This control is used to reduce the gain of the RF amplifier under strong signal conditions.

- 5. MIC GAIN CONTROL:** Adjust the microphone gain in the transmit and PA modes. This controls the gain to the extent that full talk power is available several inches away from the microphone.
- 6. FINE / COARSE:** Allows variation of the radio operating frequencies above and below the channel frequency. Although this control is intended primarily to tune in SSB signals, it may be used to optimize AM signals.
- 7. CHANNEL SELECTOR:** This switch selects any one of the forty channels desired. The selected channel appears on the LED readout directly above the Channel Selector knob.
- 8. METER:** This meter indicates received signal strength, transmitter RF output power and SWR level.
- 9. RF POWER :** This control is used to adjust the transmit power.
- 10. DIMMER:** This knob controls the level of brightness for the meter lamp, frequency digits and channel digits. It does not control the brightness of the backlit faceplate lettering. The faceplate lettering is on maximum at all times. It is very soft lighting and will not even be noticeable in daylight. However, it is very helpful at night.
- 11. OFF/SWR/NB-ANL SW :** When the switch is in the "SWR" position, the meter indicates the Standing Wave Ratio (SWR) of your antenna when you transmit - instead of indicating Power Output. No adjustments are required because the SWR circuit in this radio calibrates itself automatically. When the switch is placed in the NB/ANL position, both the RF Noise Blanker and the Automatic Noise Limiter circuits are activated. When in the OFF position, both features are OFF.
- 12. FREQUENCY COUNTER:** This blue illuminated display indicates the frequency of the selected channel.
- 13. BAND SELECTOR:** This switch allows user to select the frequency range of the channel selector
- 14. MODE SWITCH:** This control allows you to select one of the following operating modes: AM/USB/LSB.
- 15. RX/TX LED:** This LED is blue during receive and red during transmit.
- 16. SWR LED:** This LED lights red when your SWR is higher than about 3:1. This is not an exact indicator of 3:1 SWR, but it is an indication that you should check your SWR reading.

17. **CHANNEL INDICATOR:** The numbered LED indicates the selected channel you wish to operate on.

18. **ILLUMINATED FACE PLATE:** All faceplate lettering will fully illuminate to allow the user easy viewing at night. This unique, solid state, backlight is designed to maximize night vision while minimizing eye fatigue. Therefore, it is ideal for switch and control recognition day or night.

REAR PANEL

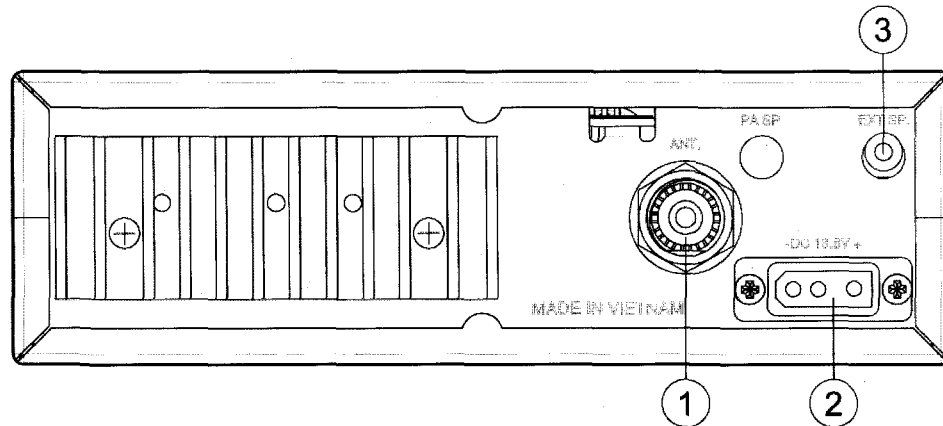

1. **ANTENNA:** This jack accepts 50 ohms coaxial cable with a PL-259 type plug.

2. **POWER:** Accepts 13.8V DC power cable with built-in fuse (10 amp.) to be connected. The power cord provided with this radio has a red and a black wire. The black goes to negative and the red goes to positive.

3. **EXT. SP:** Accepts 4 to 8 ohms, 5 watt external speaker to be connected. When external speaker is connected to this jack, the built-in speaker is automatically disconnected.

PRESS-TO-TALK MICROPHONE

The receiver and transmitter are controlled by the press-to-talk switch on the microphone. Press the switch and the transmitter is activated, release switch to receive. When transmitting, hold the microphone two inches from the mouth and speak clearly in a normal "voice". The radios come complete with low-impedance (500 ohm) dynamic microphone. For installation instruction on other microphones, see next section, "ALTERNATE MICROPHONES AND INSTALLATION".

OPERATING PROCEDURE TO RECEIVE

1. Be sure that power source, microphone and antenna are connected to the proper connectors before going to the next step.
2. Turn unit on by tuning **VOL** control clockwise on your transceiver.
3. Set the **VOLUME** for a comfortable listening level.
4. Set the **MODE** switch to the desired mode.
5. Listen to the background noise from the speaker. Turn the **SQUELCH** control slowly clockwise until the noise **JUST** disappears (no signal should be present). Leave the control at this setting. The **SQUELCH** is now properly adjusted. The receive will remain quiet until a signal is actually received. Do not advance the control too far, or some of the weaker signals will not be heard.
6. Set **CHANNEL** selector switch to the desired channel.
7. Set the **RF** gain control fully clockwise for maximum **RF** gain.

OPERATING PROCEDURE TO TRANSMIT

1. Select the desired channel of transmission.
2. Set the **MIC GAIN** control fully clockwise.
3. If the channel is clear, depress the push-to-talk switch on the microphone and speak in a normal voice.

ALTERNATE MICROPHONES AND INSTALLATION

For best results, the user should select a low-impedance dynamic type microphone or a transistorized microphone. Transistorized type microphones have a low output impedance characteristic. The microphones must be provided with a four-lead cable. The audio conductor and its shielded lead comprise two of the leads. The fourth lead is for receive control, and the third is for transmit control. The microphone should provide the functions shown in schematic below.

4 WIRE MIC CABLE	
Pin Number	Mic Cable Lead
1	Audio shield
2	Audio Lead
3	Transmit control
4	Receive Control

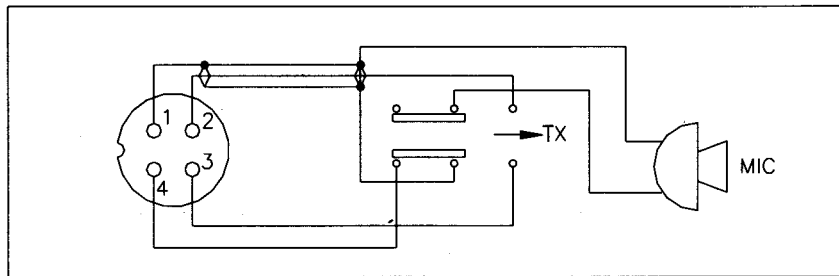

Fig. 1 Your transceiver microphone schematic.

If the microphone to be used is provided with pre-cut leads, they must be revised as follows.

1. Cut leads so that they extend 7/16" beyond the plastic insulating jacket of the microphone cable.
2. All leads should be cut to the same length. Strip the ends of each wire 1/8" and tin the exposed wire.

Before beginning the actual wiring read carefully, the circuit and wiring information provided with the microphone you select. Use the minimum head required in soldering the connections. Keep the exposed wire lengths to a minimum to avoid shorting when the microphone plug is reassembled.

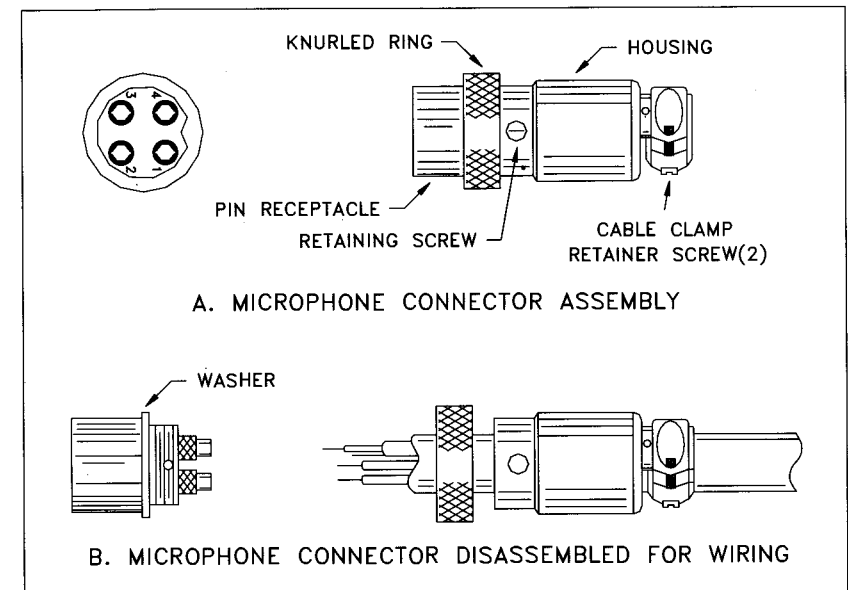

Fig. 2 Microphone plug wiring

1. Remove the retaining screw
2. Unscrew the housing from the pin receptacle body
3. Loosen the two cable clamp retainer screws.
4. Feed the microphone cable through the housing, knurled ring and washer as shown Fig. 2.
5. The wires must now be soldered to the pins as indicated in the above wiring tables. If a vise or clamping tool is available it should be used to hold the pin receptacle body during the soldering operation, so that both hands are free to perform the soldering. If a vise or clamping tool is not available, the pin receptacle body can be held in a stationary position by inserting it into the microphone jack of the front panel. The numbers of the pins of the microphone plug are shown in Fig. 3, as viewed from the back of the plug. Before soldering the wire to the pins, pre-tin the wire receptacle of each pin of the plug.

Printed in Viet Nam
P/N:A38200862V