

ASSEMBLY INSTRUCTIONS

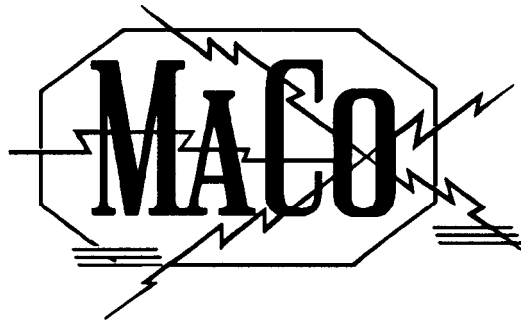

5 ELEMENT - 11 METER MAXIMUM BEAM

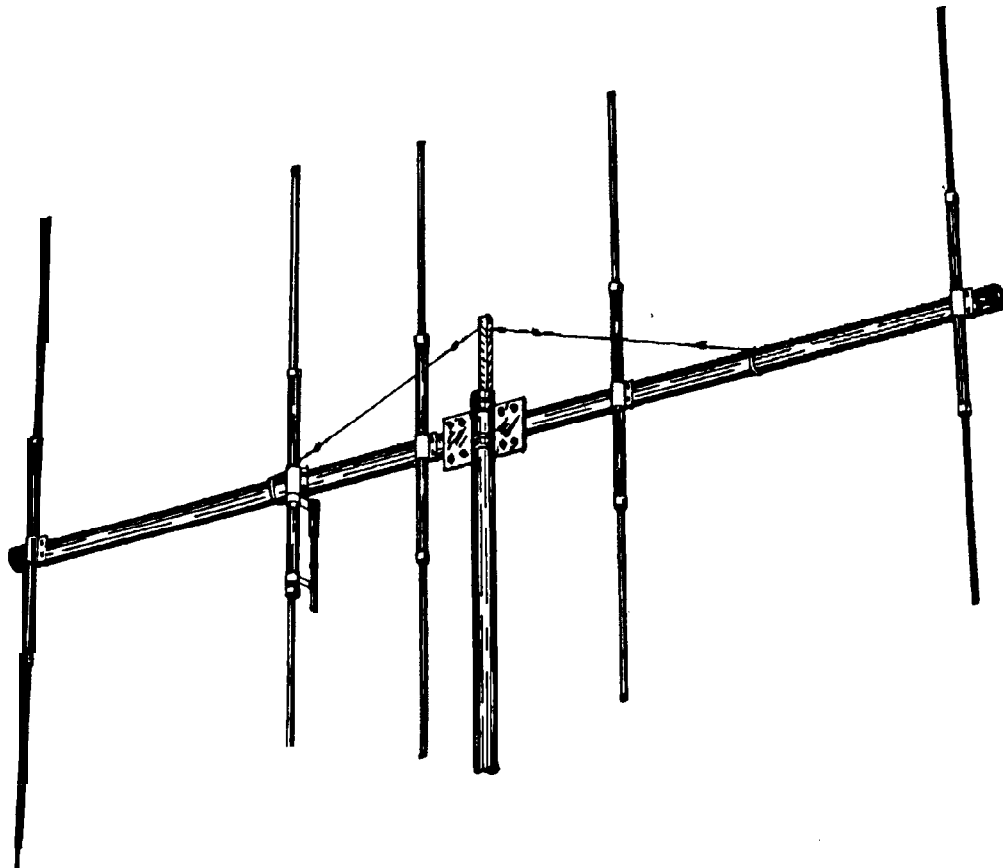

M105C

*Maco Manufacturing Co. - Division of Majestic Communications, Inc.
4091 Viscount - Memphis, Tennessee 38118 (901) 794-9494*

MACO M105C

PARTS LIST

<u>QTY</u>	<u>Q.D.</u>	<u>SIZE</u>	<u>LENGTH</u>	<u>DESCRIPTION</u>	<u>CHECKLIST</u>	
T52P	2	2"	.057"	80"	ALUM, TUBING SLOTTED ONE END	_____
T53P	1	1.845"	.060"	80"	ALUM. TUBING	_____
T32P	2	2"	.047"	80"	ALUM. TUBING SWAGED ONE END 6" (DIE #2-1.835")	_____
P01P	1		5"	8"	PLATE 2" BOOM TO 2" MAST	_____
T11P	5	5/8"	.047"	72"	ALUM. TUBING SLOTTED BOTH ENDS	_____
TO4	2	1/2"	.041"	80.5"	ALUM. TUBING	_____
T01	8		.041"	72"	ALUM. TUBING	_____
V01P	1		1" x 1"	18"	VERTICAL GUY SUPPORT	_____
WD2P	1		6/18"	25"	STEEL GUY CABLE	_____
G01P	1				GAMMA MATCH	_____
<u>HARDWARE BAG #1</u>						
U01	16		2"		PLATED U-BOLTS	_____
<u>HARDWARE BAG #2</u>						
SO1	16		2"		PLATED SADDLES	_____
<u>HARDWARE BAG #3</u>						
BE2P	5		2"		BOOM TO ELEMENT MOUNTS	_____
<u>HARDWARE BAG #4</u>						
NO1	36		5/16"		HEX NUTS	_____
NO2	32		5/16"		LOCKWASHERS	_____
W58P	10		5/8"		EXTRUDED ALUM. CLAMPS	_____
s21	14		10 - 24	1/2"	MACHINE SCREWS	_____
PL2	10		.437		PLASTIC CAPS - BLACK	_____
N11	15		10 - 24		SQUARE NUTS	_____
N18	2		5/16"		EYEBOLTS	_____
PL5R	1		2"		PLASTIC CAPS - RED	_____
PL5	1		2"		PLASTIC CAPS - BLACK	_____
EG1	4				EGG INSULATORS	_____
N12	2		#10		LOCKWASHERS	_____
Z02P	2				GAMMA STRAPS	_____
Z08P	2				GAMMA STRAPS F/COAX. CONNECTS	_____
S42	1				FEMALE COAX CONN. W/MOUNTING NUT	_____

WHEN ORDERING REPLACEMENT PARTS, ALWAYS GIVE PART NUMBER AND DESCRIPTION.

PLEASE NOTE: In an effort to keep the price on Maco Antennas down, we have decided not to clean up all the burrs and rough edges on the parts. We recommend that you deburr and clean up each part with files, sandpaper, etc. so that they go together easily. We are aware this needs to be done, but have elected not to do it to save you the money we would have to add to the price of the kit for this service.

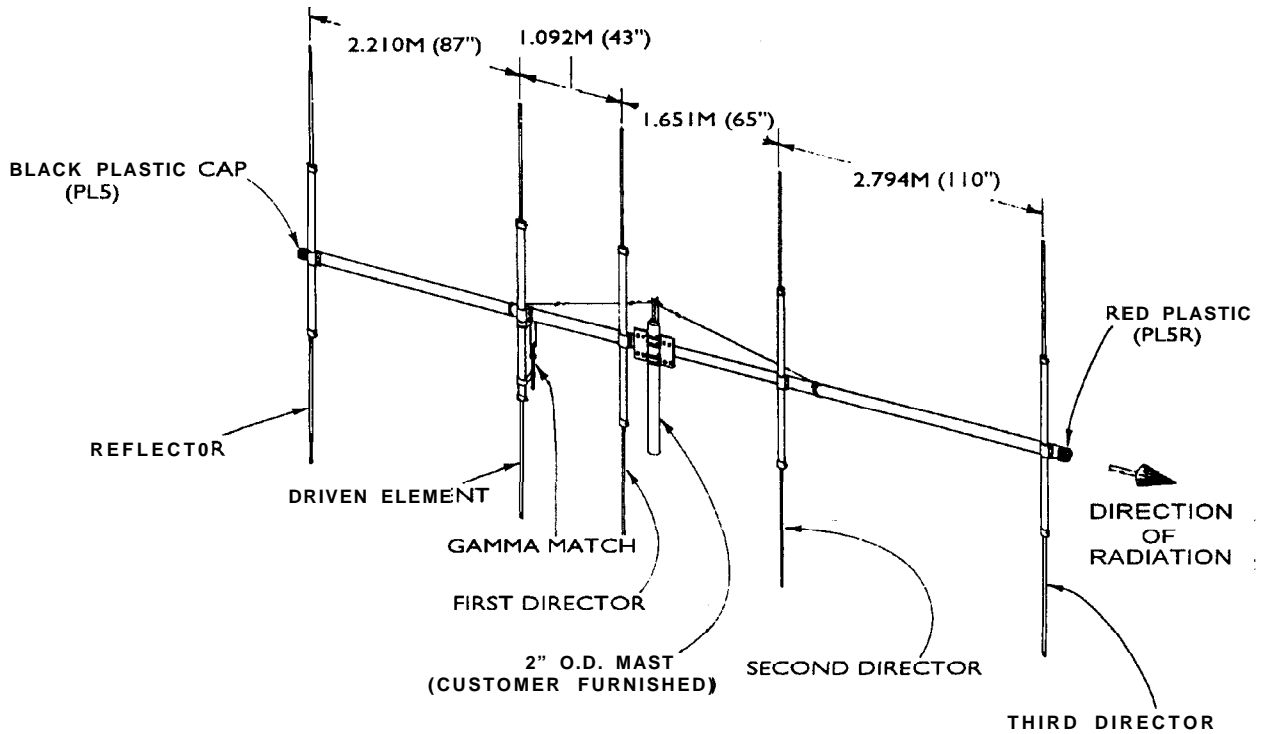

FIGURE 1A

VERTICAL POLARIZATION

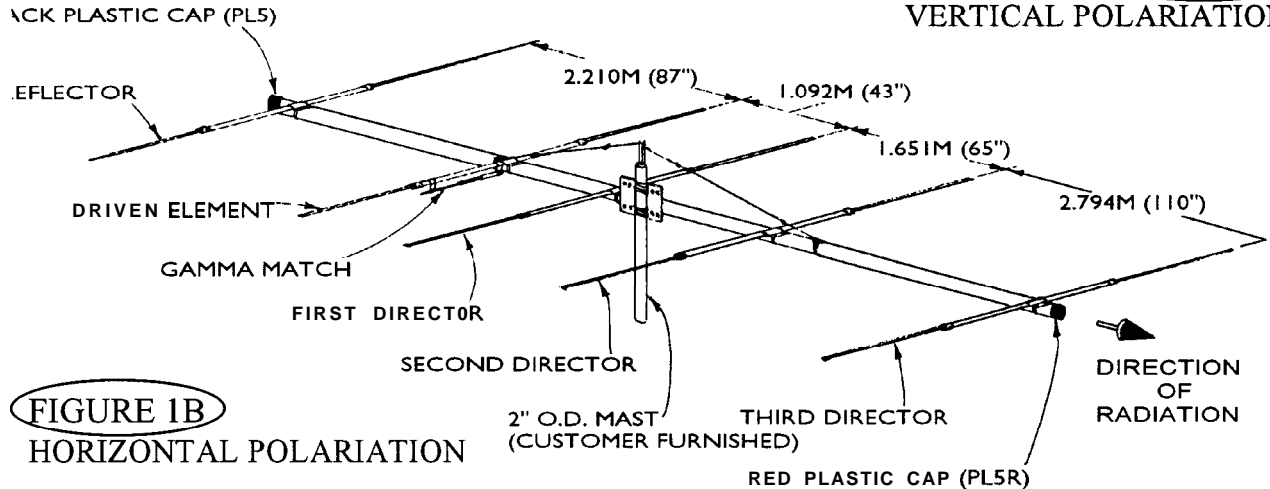

FIGURE 1B

HORIZONTAL POLARIZATION

FIGURE 1 GENERAL INSTRUCTIONS

This drawing shows a view of the antenna assembled. The M105C may be used vertically or horizontally. These instructions and FIGURES 2 through 4 show the correct assembly instructions. It is highly recommended that rope be put in the elements to prolong their life. All hardware should be tightened securely, and then coated with silicon rubber sealant or similar compound to prevent loosening from wind vibration.

Take care to locate all parts accurately per dimensions given. Complete each step as instructed before going on to following steps.

Upon completion of assembly, install the red plastic cap (PL4R) on the director end of the antenna, and the black plastic cap (PL4) on the reflector end. This will allow you to determine at a glance the direction of transmit and receive.

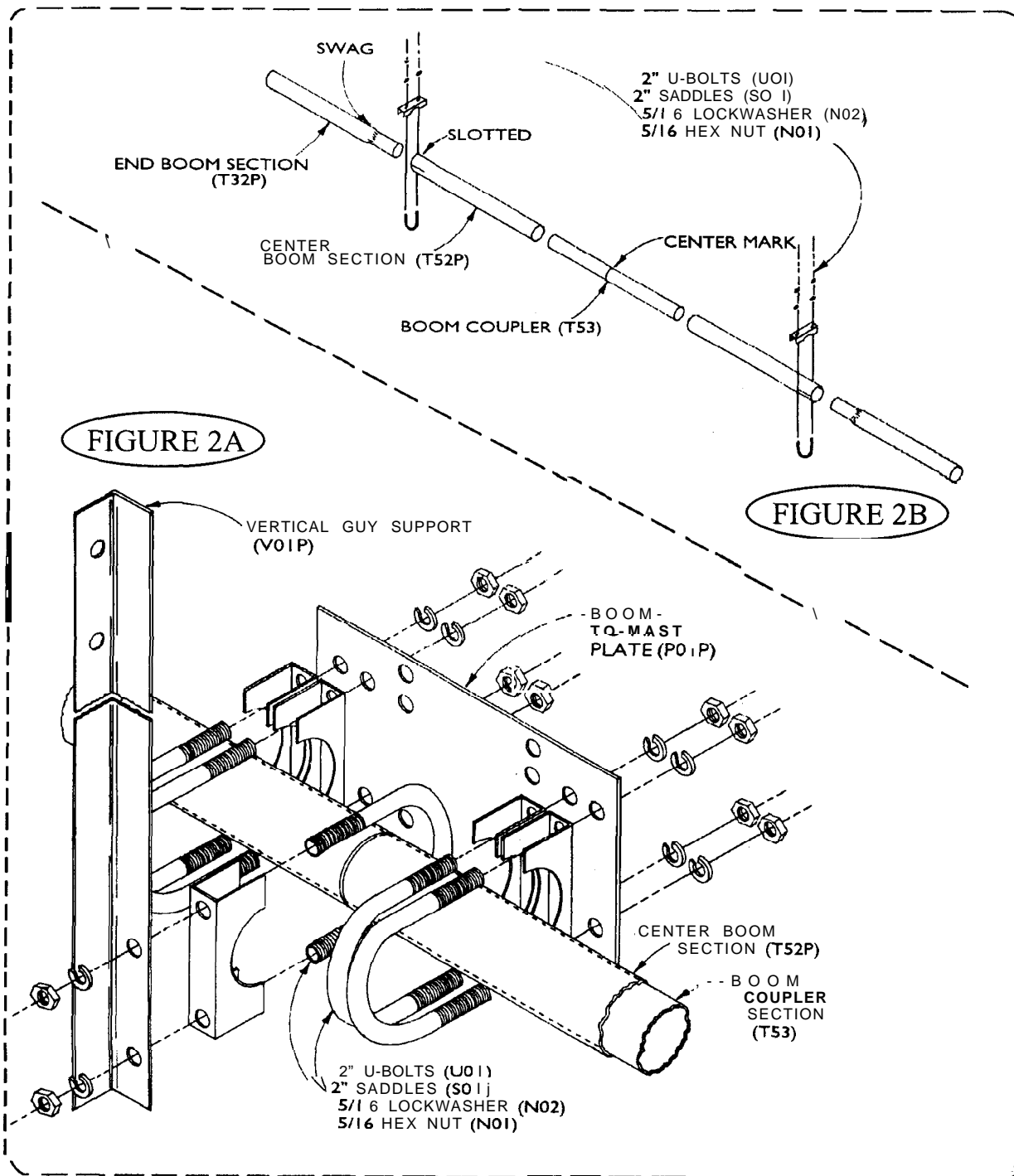

FIGURE 2 BOOM ASSEMBLY

First mark the center of the boom coupler (T53), then slide the unslotted ends of the center boom sections (T52P) over each end of the coupler so they butt at the center mark.

Attach the boom-to-mast plate (P01P) and the vertical guy support (V01P) at the boom center using 2" U-bolts, saddles and hardware as shown in Figure 2A. Be sure to slip the 2" U-bolt for attaching the guy support over the boom before securing the mast plate (P01P).

Slide the swaged ends of the end booms sections (T32P) 5" into the slotted ends of the center boom section and secure in the same manner as above. The overall length of the boom should be approximately 309". If not, adjust the end sections equally until the overall length is at least 309".

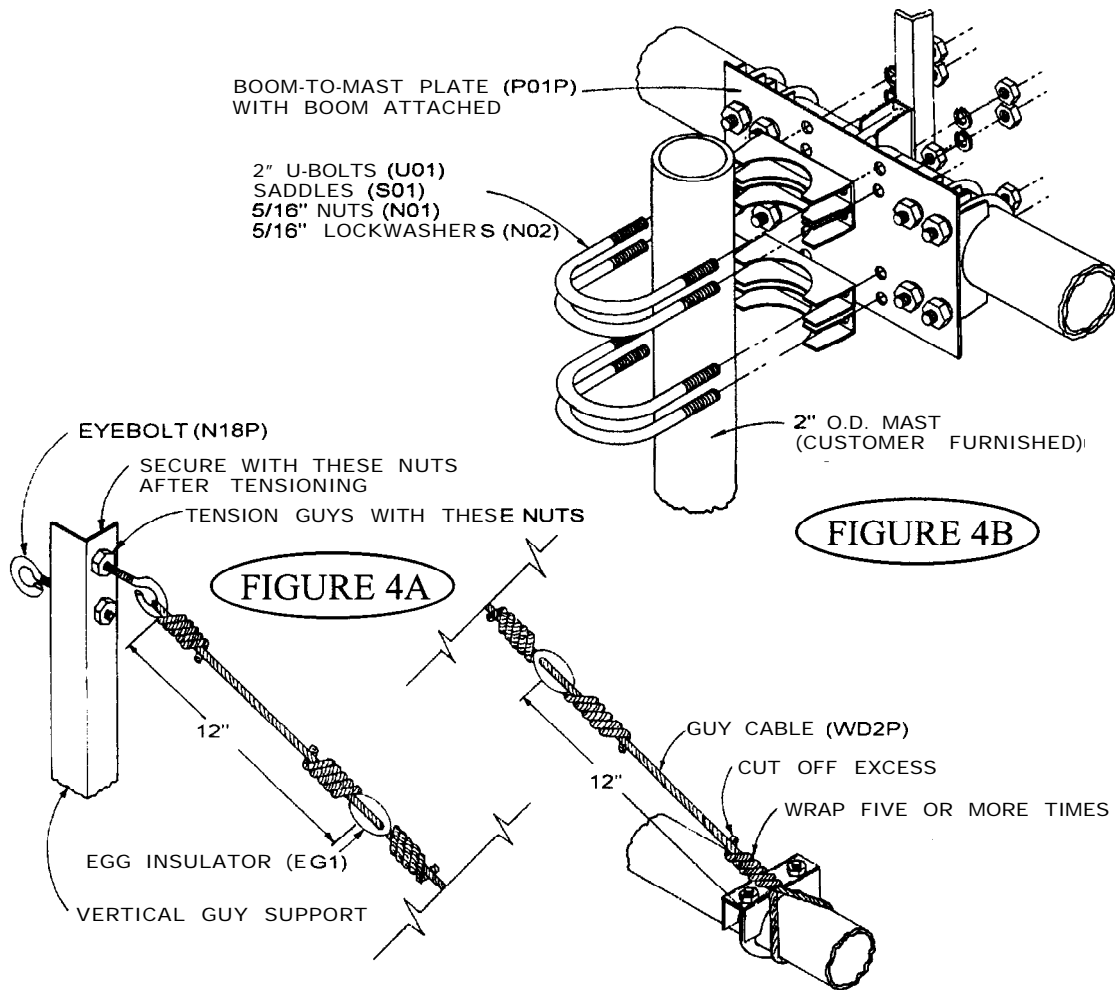

FIGURE 4 GUY ASSEMBLY

Cut four pieces of guy cable .762M (30") and two pieces 2.082M (82"). Assemble 5/16" hex nut (NO 1) onto each of the eyebolts (N18). Turn the nut all the way to the eye; as far as it will go with light pressure only. These will be used to secure the eyebolts after guy tensioning.

Install eyebolts into the top holes of the vertical guy support (V01P)- one eye each direction. Thread a hex nut about six turns onto each eyebolt.

Install a egg insulator (EG1) on one end of each .762M (30") guy cable and wrap it five or more times. Take two of these cables and install one on each eyebolt leaving .304M (12") between the egg insulator and the eyebolt, wrap it five or more times and cut off the excess. Take the other two cables with insulators and wrap each around the boom just in front of the clamp as shown in Figure 4A. Wrap and cut off excess.

Using the remaining two pieces of cable, take one end and thread it through the top egg insulator. Wrap and cut off excess. Thread the other end through the lower insulator and pull tight enough to remove slack only. Wrap and cut off excess.

Tension guys by tightening the nuts on the ends of the eyebolts. Secure with the nuts on the opposite end near the eye.

Line the elements up with the use of a level or any other workable method. Double check the spacing dimensions and make sure the elements are centered in the boom-to-element clamps. Tighten all hardware taking care to line the elements up with the use of a level. Check your measurements and make sure the elements are centered on the boom.

CB FREQUENCIES (11 METER BAND)

CHANNEL	FREQUENCY	REFLECTOR		DRIVEN		1st DIRECTOR		2nd DIRECTOR		3rd DIRECTOR	
		"A"	"B"	"A"	"B"	"A"	"B"	"A"	"B"	"A"	"B"
1-3	26.965/26.985	5.638 - (222")	1.699M (75")	5.359M (211")	1.765M (69.5")	5.130M (202")	1.638M (65")	5.080M (200")	1.612M (64")	5.029M (198")	1.600M (63")
4-7	27.005/27.035	5.638 - (222")	1.699M (75")	5.359M (211")	1.765M (69.5")	5.130M (202")	1.638M (65")	5.080M (200")	1.612M (64")	5.029M (198")	1.600M (63")
8-11	27.055/27.085	5.638 - (222")	1.699M (75")	5.359M (211")	1.752M (69")	5.130M (202")	1.638M (65")	5.080M (200")	1.612M (64")	5.003M (197")	1.587M (62.5")
12-15	27.105/27.135	5.613 - (221")	1.686M (74.5")	5.334M (210")	1.752M (69")	5.105M (201")	1.625M (64.5")	5.054M (199")	1.612M (63.5")	5.003M (197")	1.587M (62.5")
16-19	27.155/27.185	5.613M (221")	1.686M (74.5")	5.334 - (210")	1.752 - (69")	5.105M (201")	1.625 - (64.5")	5.054M (199")	1.612 - (63.5")	5.003 - (197")	1.587M (62.5")
20-25	27.205/27.245	5.613M (221")	1.686M (74.5")	5.334M (210")	1.739M (68.5")	5.105M (201")	1.625 - (64.5")	5.054M (199")	1.612 - (63.5")	4.978M (196")	1.574M (62")
26-29	27.265/27.295	5.588 - (220")	1.674M (74")	5.308 - (209")	1.739M (68.5")	5.080 - (200")	1.625 - (64")	5.029M (198")	1.600 - (63")	4.978M (196")	1.574M (62")
30-34	27.305/27.345	5.588 - (220")	1.674 - (74")	5.283 - (208")	1.727 - (68")	5.080 - (200")	1.625 - (64")	5.029M (198")	1.600 - (63")	4.978M (196")	1.574M (62")
35-39	27.355/27.395	5.562 - (219")	1.661M (73.5")	5.283 - (208")	1.727 - (68")	5.080 - (200")	1.625 - (64")	5.003 - (197")	1.587 - (62.5")	4.953M (195")	1.562 - (61.5")
40	27.405	5.562M (219")	1.661 - (73.5")	5.283 - (208")	1.727 - (68")	5.054M (199")	1.612 - (63.5")	5.003 - (197")	1.587 - (62.5")	4.953M (195")	1.562 - (61.5")

AMATEUR FREQUENCIES (10 METER BAND)

FREQUENCY	PHONE 28.600 MHz		CW 28.100 MHz		OSCAR 29.500 MHz		FM 29.600 MHz	
	"A"	"B"	"A"	"B"	"A"	"B"	"A"	"B"
REFLECTOR	5.232M (206")	1.496M (67")	5.334M (210")	1.547M (69")	5.080M (200")	1.420M (64")	5.080M (200")	1.420M (64")
DRIVEN	4.978M (196")	1.574M (62")	5.080M (200")	1.625M (64")	4.826M (190")	1.498M (59")	4.826M (190")	1.498M (59")
1st DIRECTOR	4.800M (189")	1.485M (58.5")	4.876M (192")	1.524M (60")	4.648M (183")	1.409M (55.5")	4.622M (182")	1.397M (55")
2nd DIRECTOR	4.699M (185")	1.435M (56.5")	4.775M (188")	1.473M (58")	4.546M (179")	1.358M (53.5")	4.521M (178")	1.346M (53")
3rd DIRECTOR	4.699M (185")	1.435M (56.5")	4.775M (188")	1.473M (58")	4.546M (179")	1.358M (53.5")	4.521M (178")	1.346M (53")

***NOTE:** THESE DIMENSIONS ARE APPROXIMATE. REFER TO THE INSTRUCTIONS ON ADJUSTING THE S.W.R. TO DETERMINE EXACT SETTINGS. THERE ARE 2 SEPARATE GAMMA ADJUSTMENTS, 1. CAPACITOR ADJUSTMENT, 2. SLIDER POSITION. **DO NOT MOVE BOTH AT THE SAME TIME.** MOVE THE CAPACITOR FIRST, THEN, IF NECESSARY MOVE THE SLIDER, AND GO BACK TO THE CAPACITOR.

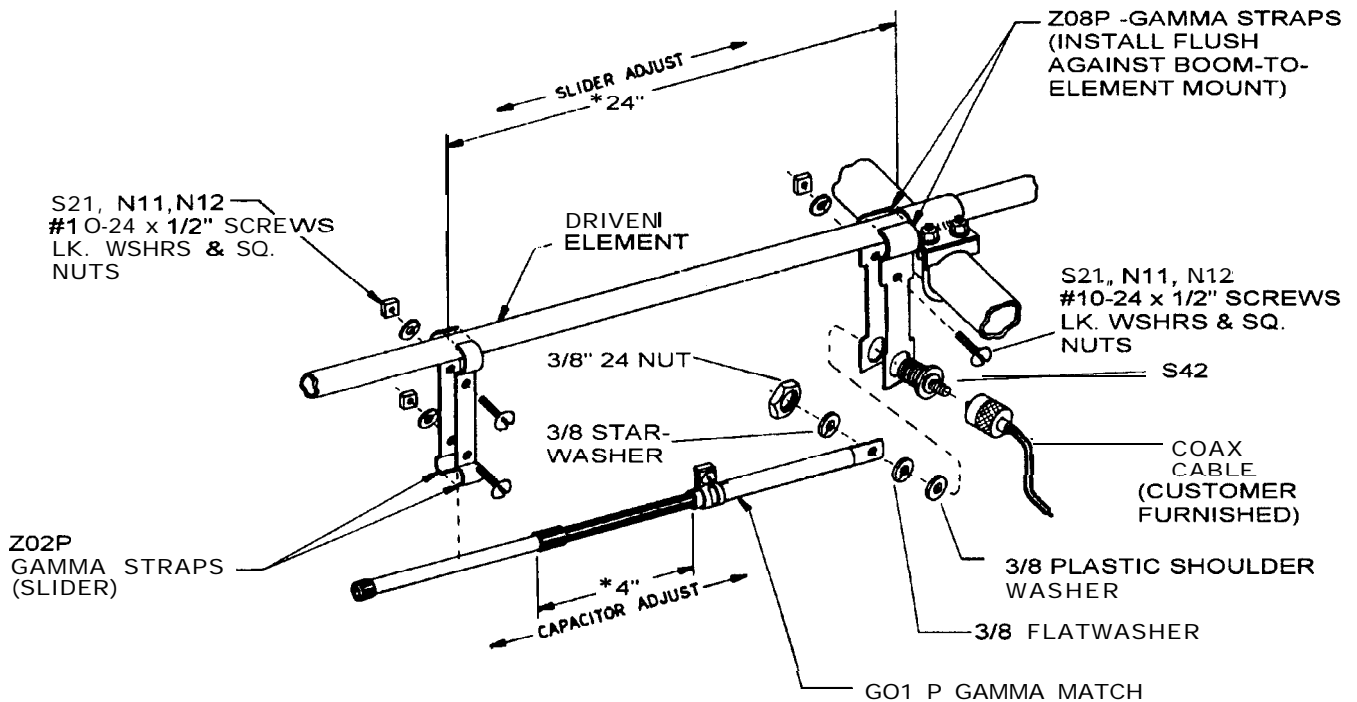

FIGURE 4 GAMMA MATCH MOUNTING

Mount the gamma match (GO 1P) to the driven element, using the gamma straps (Z02P, Z08P) and attaching hardware as shown. Attach your 52 ohm coaxial cable to the connector (S42) and dress along boom and down the mast. The gamma is shown pointing down - this is to let water out.

ADJUSTING THE STANDING WAVE RATIO (SWR)

Refer to Figure 4. The dimensions given are approximate and should be used as a starting point.* The gamma match has 2 adjustments. First is the capacitor adjust and second is the slider adjust. Connect a SWR bridge coax between your transmitter and the antenna and check the SWR. If adjustment is required, loosen the clamp on the gamma match and the screws holding the slider (gamma straps (Z02P)). Next move the capacitor adjustment first one direction, then the other until a minimum SWR reading is obtained. If SWR is not yet satisfactory, move the slider out 2" away from the boom. If the reading has gone up move the slider back to the original position and then 2" towards the boom. Now readjust the capacitor for minimum SWR. You should now be able to determine which direction to move the slider. Repeat the above procedure moving the slider in smaller increments until a satisfactory SWR is obtained. Tighten all hardware. Disconnect the SWR bridge and reconnect your coaxial cable.

NOTE!

When assembling for vertical use, set antenna on a pole about 8 to 9 feet above the ground horizontally and adjust SWR to 1.7. When you turn the antenna vertical and mount it on the tower, etc., the SWR will drop to 1.4 to 1.5. This is good; QUIT! Antenna results best if vertical antenna clears the top of the tower.