

# ASSEMBLY INSTRUCTIONS

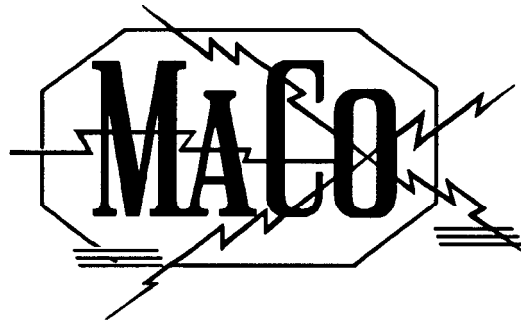

## SWITCHABLE POLARITY 12 ELEMENT LASER BEAM

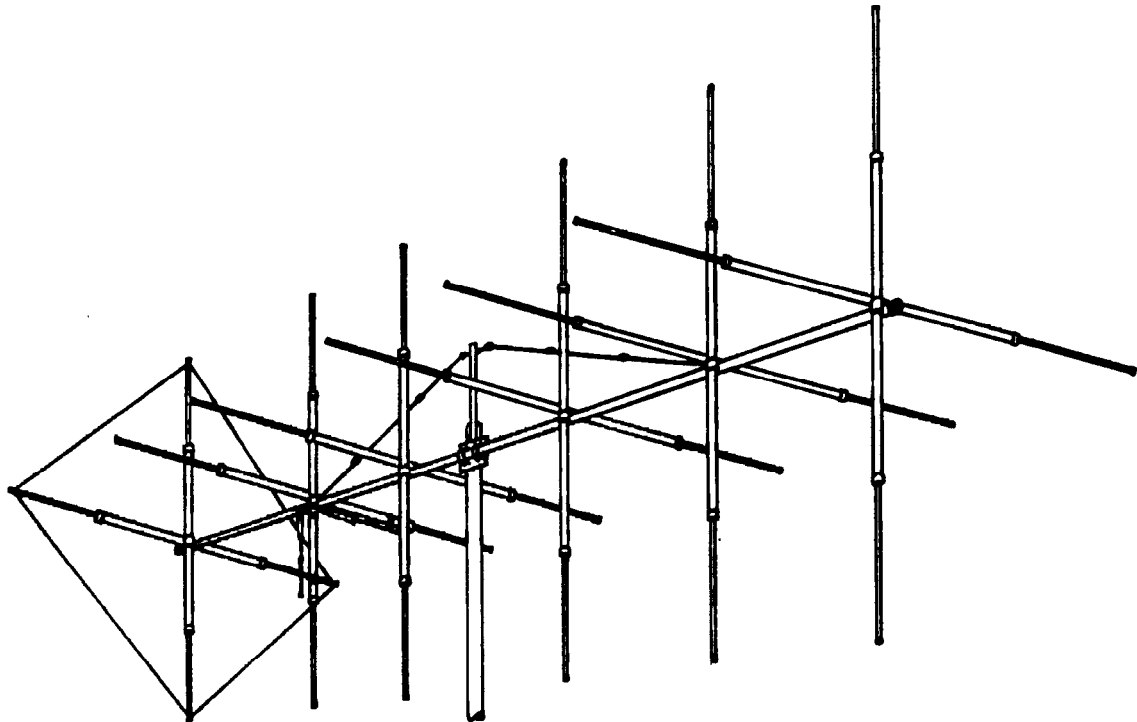

## LASER 400

---

*Maco Manufacturing Co. - Division of Majestic Communications, Inc.  
4091 Viscount - Memphis, Tennessee 38118 (901) 794-9494*

# MACOLASER400

## PARTS LIST

<u>PART</u>	<u>Y</u>	<u>O.D.</u>	<u>SIZE</u>	<u>LENGTH</u>	<u>DESCRIPTION</u>	<u>CHECKLIST</u>
TO1	20	1/2"	.035"	72"	Alum. Tubing	_____
T11P	1 2	5/8"	.047"	72"	Alum. Tubing Slotted Both Ends	_____
T31P	2	2"	.047"	80"	Alum. Tubing Swage One End to 1.835" & Sl to Other End 3"	_____
T52P	2	2"	.057"	80"	Alum. Tubing Slot One End 3"	_____
T53P	1	1.845"	.060"	80"	Alum. Tubing	_____
T57P	2	2"	.047"	36"	Alum. Tubing Swage One End to 1.875"	_____
P01P	1		5"x1/4"	8"	2" Boom To 2" Mast Plate	_____
VO3P	1		1" x 1"	24"	Vertical Guy Support	_____
WD4P	1		6/18	30'	Steel Guy Cable	_____
W04P	1		14 GA.	40'	Bare Copper Wire -14/7	_____
FA1P	4				Fiberglass Rods	_____
G01P	2				11 Meter Gamma Matches	_____

### HARDWARE BAG #1

EG1	4				Egg Insulators	_____
N18P	2		5/16"	4"	Eyebolts - Welded	_____
PL2	20		.437"		Plastic Caps - Black	_____
PL5	1		2"		Plastic Cap - Black	_____
PL5R	1		2"		Plastic Cap - Red	_____
NO1	54		5/16"		Hex Nuts	_____
N02	50		5/16"		Lockwashers	_____
N11	36		10-24		Square Nuts	_____
N12	12		#10		Lockwashers	_____
N26	4		#10		Flat Washer	_____
s21	34		1 0-24	1/2"	Machine Screws	_____
W58P	2 4		5/8"		Extruded Alum. Clamps	_____
Z02P	4				Gamma Straps	_____
Z08P	4				Gamma Straps f/coax. connectors	_____
S42	2				Female Coax. Connectors W/Mtg.Nut	_____

### HARDWARE BAG #2

U01	25		2"		Plated U-Bolts	_____
-----	----	--	----	--	----------------	-------

### HARDWARE BAG #3

S01	25		2"		Plated Saddles	_____
-----	----	--	----	--	----------------	-------

### HARDWARE BAG #4

BE2P	1 2				Boom To Element Mounts	_____
------	-----	--	--	--	------------------------	-------

WHEN ORDERING REPLACEMENT PARTS, ALWAYS GIVE PART NUMBER AND DESCRIPTION.

PLEASE NOTE: In an effort to keep the price on Maco Antennas down, we have decided not to clean up all the burrs and rough edges on the parts. We recommend that you deburr and clean up each part with files, sandpaper, etc. so that they go together easily. We are aware this needs to be done, but have elected not to do it to save you the money we would have to add to the price of the kit for this service.

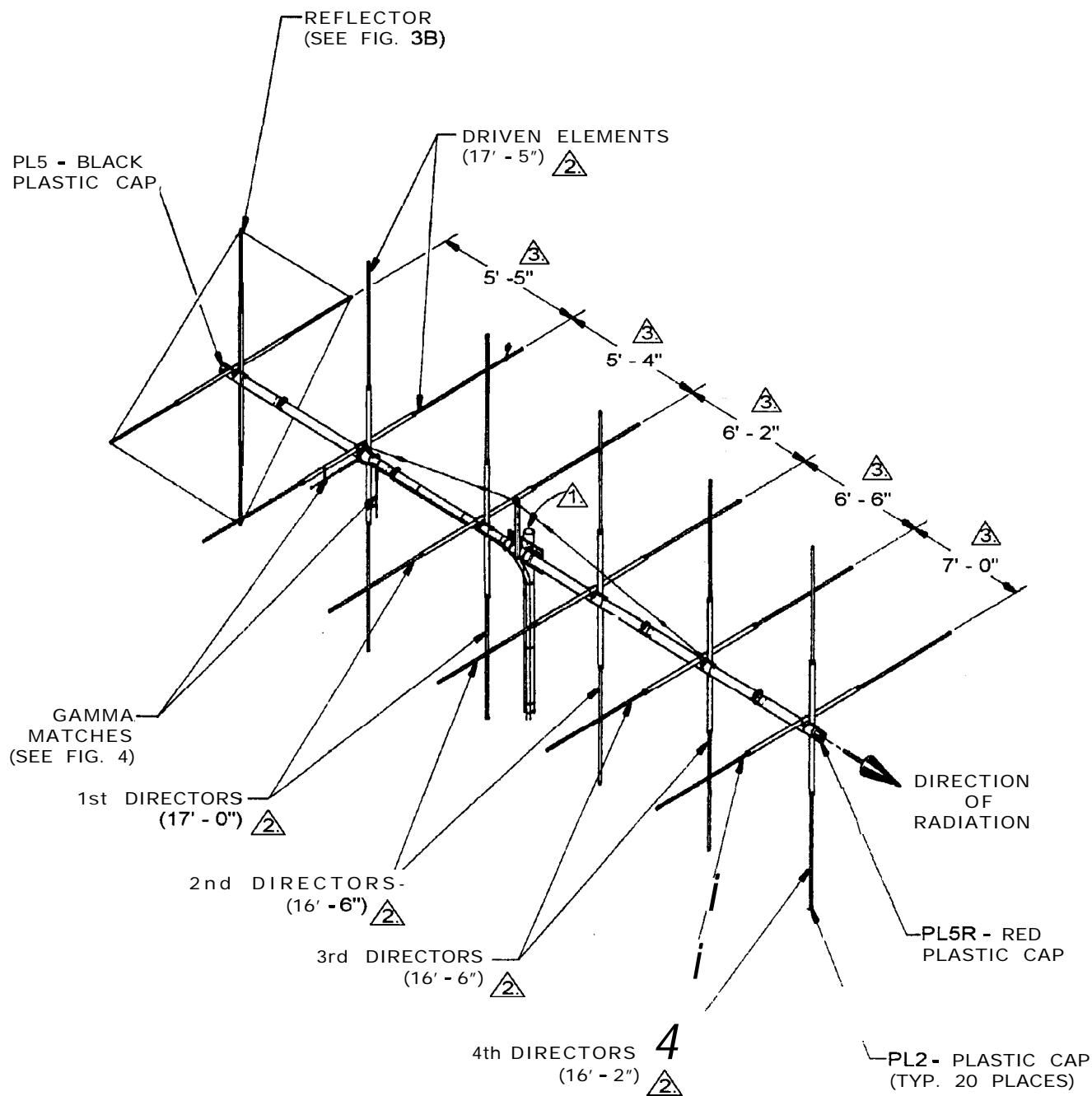

NOTES:

1. FOR DETAILS OF BOOM & GUY ASSEMBLY AND MAST MOUNTING, SEE FIG. 2.
2. FOR DETAILS OF ELEMENT ASSEMBLY AN MOUNTING, SEE FIG. 3.
3. HORIZONTAL & VERTICAL ELEMENT SPACING DIMENSIONS ARE IDENTICAL WITHH 1/4" GAP BOOM-TO-ELEMENT MOUNTS, SEE FIG. 3C.

# LASER 400

FIGURE 1

# MACO LASER 400

## ASSEMBLY INSTRUCTIONS

### FIGURE 1. GENERAL INSTRUCTIONS

This drawing depicts an overall view of what the antenna should look like upon completion of assembly. Refer to Figures 2 thru 4 for specific assembly details. All hardware should be coated with a silicon rubber sealant or similar compound to insure that wind vibration does not cause it to work loose. Upon completion of assembly, install the red plastic cap (PLSR) on the director end of the antenna, and the black plastic cap (PL5) on the reflector end. This will allow you to determine at a glance the direction of transmit and receive.

### FIGURE 2. BOOM & GUY ASSEMBLY

To assemble the boom, first mark the center of the boom coupler (T53), and slide the unslotted ends of the center boom sections (T52P) over each end of the coupler so that they butt in the center. Next attach the boom-to-mast plate (POIP) and the vertical guy support (VO3P) at the boom center using 2' U-bolts, saddles and hardware as shown. (Refer to Detail 2A)

Now, slide the **swaged** ends of the intermediate boom sections (T31P) into the slotted ends of the center boom sections. Secure with 2' U-bolts, saddles and hardware as shown (Refer to Detail 2B) Next, slide the **swaged** ends of the end boom sections (T57P) into the slotted ends of the intermediate boom sections and secure in the same manner. (Refer to Detail 2B)

The first step in assembling the guy cable is to cut four lengths of 2 feet each off the roll of cable. Take two 2 foot lengths and attach one end of each to an egg insulator (EGI) and the other end to an **eyebolt** (N18) so that the distance between the **eyebolt** and insulator is 1 foot. Attach both **eyebolts** to the vertical guy support with 5/16" hex nuts as shown in detail 2C. Run the outside hex nuts only a couple of turns onto the ends of the **eyebolts** and leave the inside nuts loose so that you can take the slack out of the cable later. Now take both 2 foot lengths and attach an egg insulator to one end of each in the same manner. (At this point, it is necessary to go on to element assembly and mounting, before completing the guy cable assembly.)

Take the 2 foot cable lengths with the egg insulators attached and fasten one to the boom at the driven element and the other at the 3rd director. Wrap as shown in detail 2D. so that the distance between the boom and insulator is 1 ft.

Now take the remaining cable and allowing approximately 9 inches at each end for wrapping, stretch it between the insulators on one end of the boom and cut it off. Leaving as little slack as possible, wrap each end of the cable around the insulators as shown in details 2C and 2D. Do the same thing for the cable on the other end of the boom.

Take the rest of the slack out of the cables by tightening the outside hex nuts on the eyebolts. Lock them in place by tightening the inside hex nuts.

This antenna is designed for mounting on a 2' O.D. heavy duty mast. Mount using 2' U-bolts, saddles and hardware as shown in Detail 2E.

**CAUTION: TAKE CARE TO AVOID ANY CONTACT WITH OVERHEAD POWERLINES WHEN RAISING YOUR ANTENNA. SERIOUS OR FATAL INJURY COULD RESULT.**

### FIGURE 3 ELEMENT ASSEMBLY

Prior to assembling elements slide a boom-to-element mount (**BE2P**) onto each of the (12) element center sections (**TIIP**). Assemble each element as shown using the clamps and hardware specified. Refer to the element table to determine dimensions for each element. Install a black plastic cap (**PL2**) onto both ends of each element. Assemble the reflector elements in the same manner, sliding the fiberglass arms approximately 6 inches into the ends of the center sections (**TIIP**). Snug the clamps but don't tighten at this time because the arms will have to be adjusted after installing the reflector wire.

### FIGURE 3B ELEMENT MOUNTING

Mark each element at the center and be sure that the boom-to-element mounts (**BE2P**) are centered on the elements before tightening hardware. Starting 1" from the director end of the boom, mount each element using 2" U-bolts, saddles, boom-to-element mounts and hardware as shown. Refer to Figures 1 & 3B for element spacing dimensions. (At this point go back and complete the guy cable assembly.)

### FIGURE 3C REFLECTOR ASSEMBLY

The length of the reflector wire is very critical. It must be the correct length to operate correctly. Take the wire (**WO4P**) and uncoil it making sure that there are no kinks; secure it to a nail. Pull the wire until it stretches an inch or so. The easy way to get the correct length for the reflector loop is as follows:

1. Drive 2 nails in a board or fence 1/2 the length of the loop apart --which is 225-1/2" between them.
2. Stretch the wire around the nails by hand as tightly as possible and splice ends together. Solder the splice. Remove one nail and remove the loop. Cut any excess wire off.
3. Loosely assemble the machine screws (**S21**), flatwashers (**N26**), lo&washers (**N12**), and hex nuts (**N06**) onto the lugs of the fiberglass arms, adjusting the length as shown.
4. Tighten 3 of the 4 clamps that hold the fiberglass rods.
5. Install the wire as shown.
6. Tighten the wire by pulling the fourth fiberglass rod until the wire is the same tightness as it was around the nails. The wire loop is now the correct length. Note the total length of the loop is critical, and also is the length of each side. REMEMBER: Reflector dimensions are only preliminary. Change to get equal sides of 9' 4-3/4" . Fiberglass length is not critical, however the equal wire length of 9' 4-3/4" is very critical.

### FIGURE 4 GAMMA MATCH MOUNTING

Mount the (2) gamma matches (**G01P**) to the horizontal and vertical driven elements, using the gamma straps (**Z02P**, **Z08P**) and attaching hardware as shown. Attach your 52 ohm coaxial cables to the connectors (**S42**) and dress along boom and down the mast.

### ADJUSTING STANDING WAVE RATIO

Refer to Figure 4. The dimensions given are approximate and should be used as a starting point. The following instructions cover the adjustment of one gamma match. To adjust the second gamma match, simply repeat this procedure.

The gamma match has 2 adjustments. First is the capacitor adjust and the second is the slider adjust. Connect a S.W.R bridge to the coax between your transmitter and the antenna and check the S.W.R. If adjustment is required loosen the clamp on the gamma match and the screws holding the slider (Gamma Straps **Z02P**). Next move the capacitor adjustment first in one direction then the other until a minimum S.W.R. reading is obtained. If S.W.R. is not yet satisfactory, move the slider out 2" away from the boom. If the reading has gone up, move the slider back to the original position and then 2" toward the boom. Now readjust the capacitor for minimum S.W.R. you should now be able to determine which direction to move the slider. Repeat the above procedure moving the slider in smaller increments until a satisfactory S.W.R. reading is obtained. Tighten all hardware. Disconnect the S.W.R. bridge and reconnect your coaxial cable.

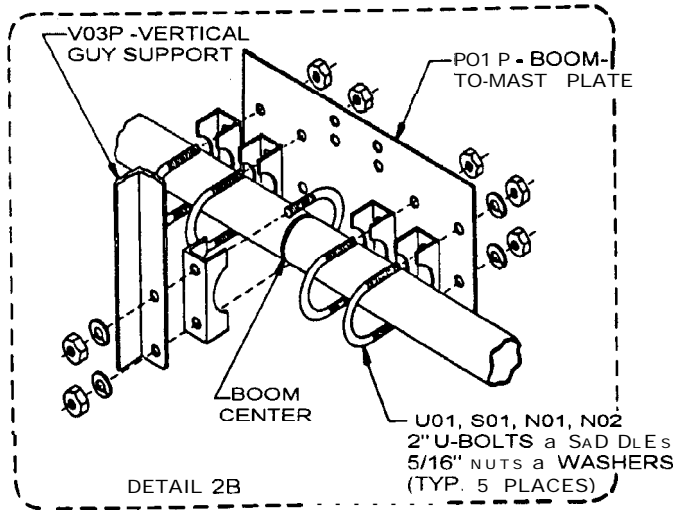
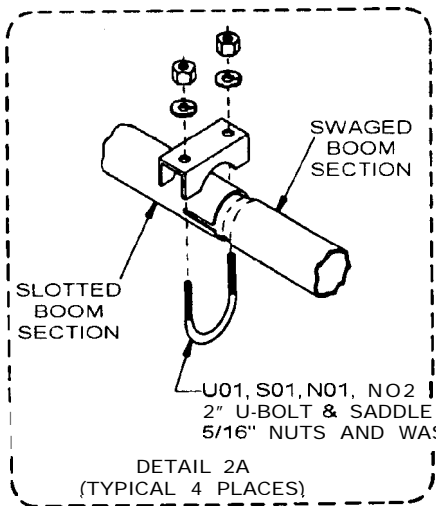

**\*NOTE:**  
HORIZONTAL ELEMENTS ONLY ARE SHOWN FOR REFERENCE. SEE FIGURE 3B FOR ELEMENT MOUNTING DETAILS

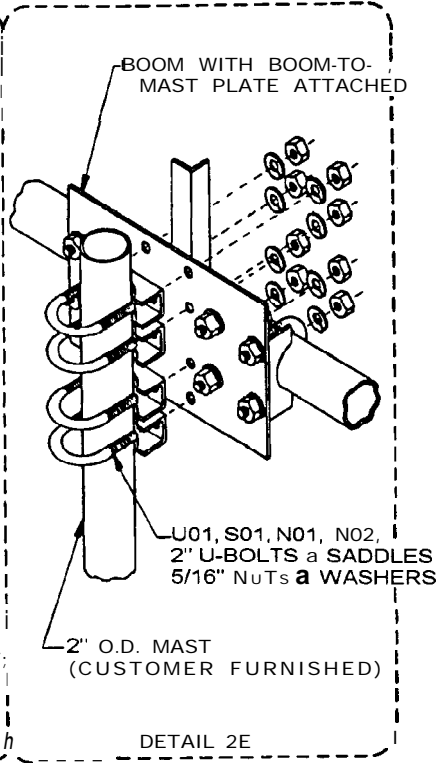
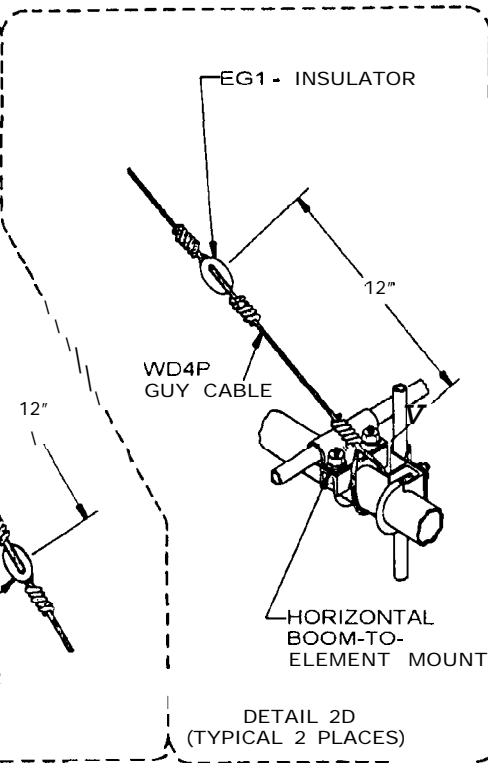
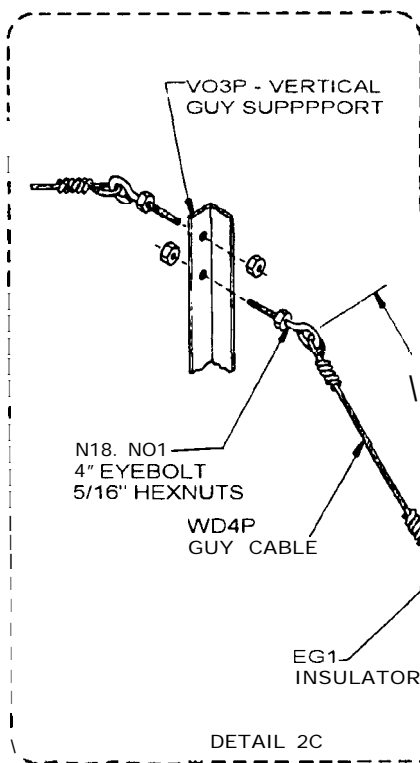
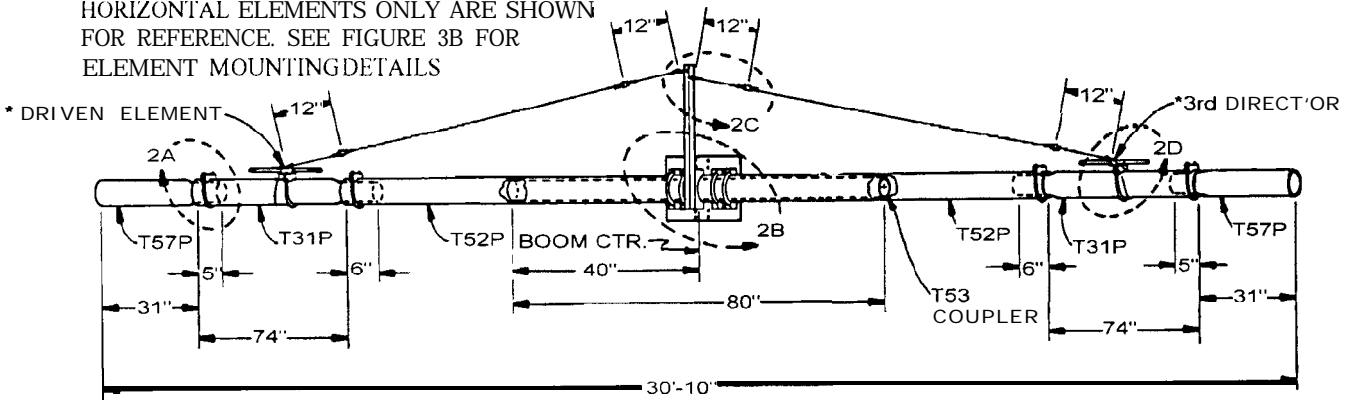
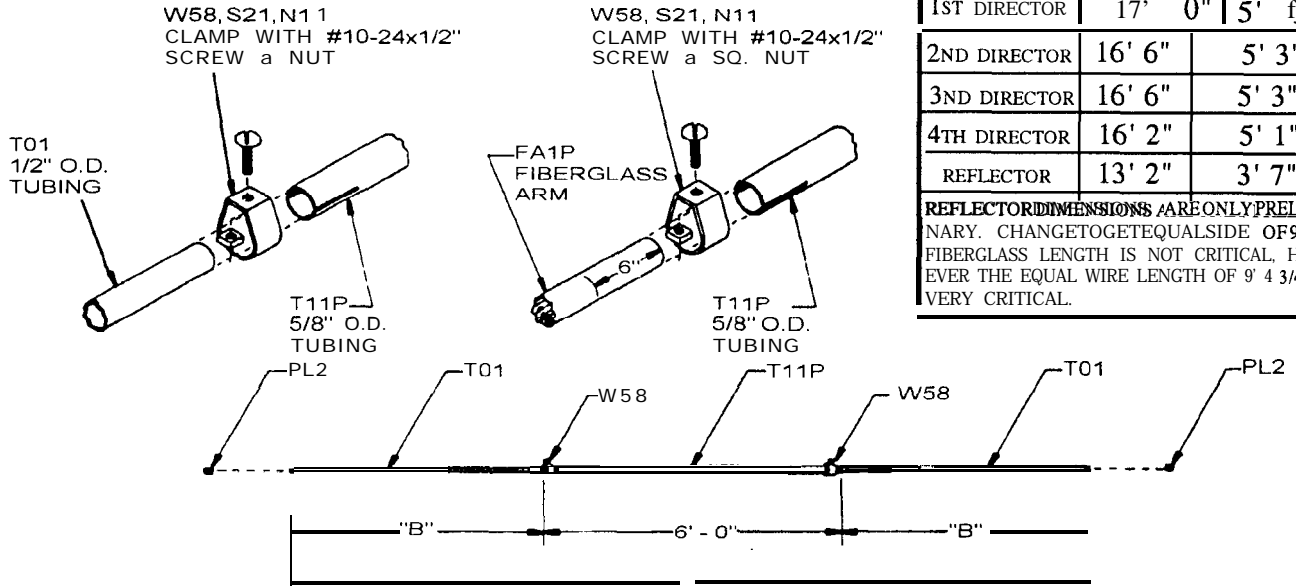

FIGURE 2

	DIMENSION	
	A	B
DRIVEN	17' 5"	5' 8-1/2"
1ST DIRECTOR	17' 0"	5' 7"
2ND DIRECTOR	16' 6"	5' 3"
3ND DIRECTOR	16' 6"	5' 3"
4TH DIRECTOR	16' 2"	5' 1"
REFLECTOR	13' 2"	3' 7"

REFLECTOR DIMENSIONS ARE ONLY PRELIMINARY. CHANGE TO GET EQUAL SIDE OF 9' 6". FIBERGLASS LENGTH IS NOT CRITICAL, HOWEVER THE EQUAL WIRE LENGTH OF 9' 4 3/4" IS VERY CRITICAL.



ELEMENT ASSEMBLY (FIGURE 3A)

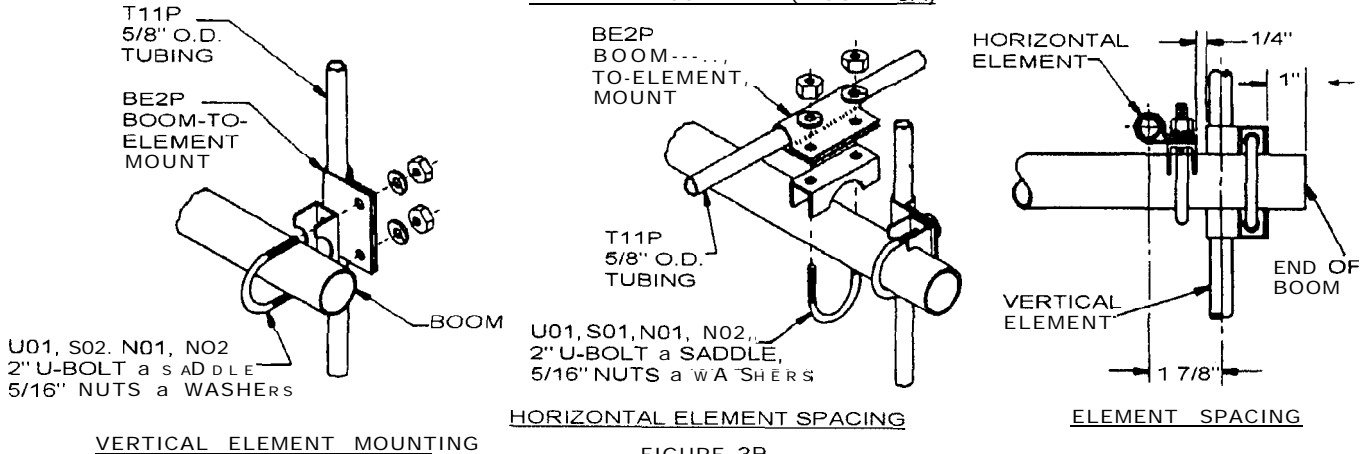

VERTICAL ELEMENT MOUNTING

FIGURE 3B

ELEMENT SPACING

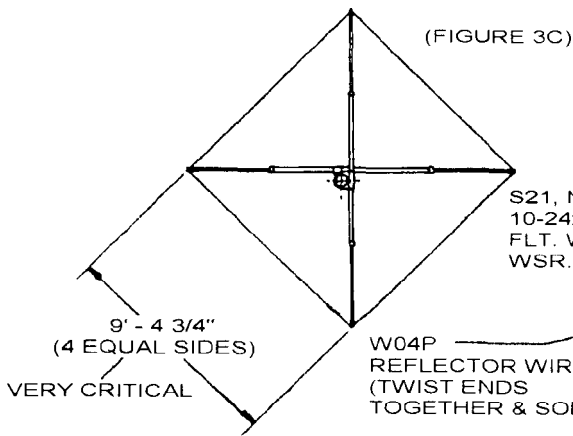

Please read the Assembly and Troubleshooting Tips at the end of this instruction booklet before assembling elements.

FIGURE 3

\* NOTE: THESE DIMENSIONS ARE APPROXIMATE. REFER TO THE INSTRUCTIONS ON ADJUSTING THE S.W.R. TO DETERMINE EXACT SETTINGS. THERE ARE 2 SEPARATE GAMMA ADJUSTMENTS, 1. CAPACITOR ADJUSTMENT, 2. SLIDER POSITION.

**DO NOT MOVE BOTH AT THE SAME TIME.** MOVE THE CAPACITOR FIRST, THEN, IF NECESSARY MOVE THE SLIDER, AND GO BACK TO THE CAPACITOR.

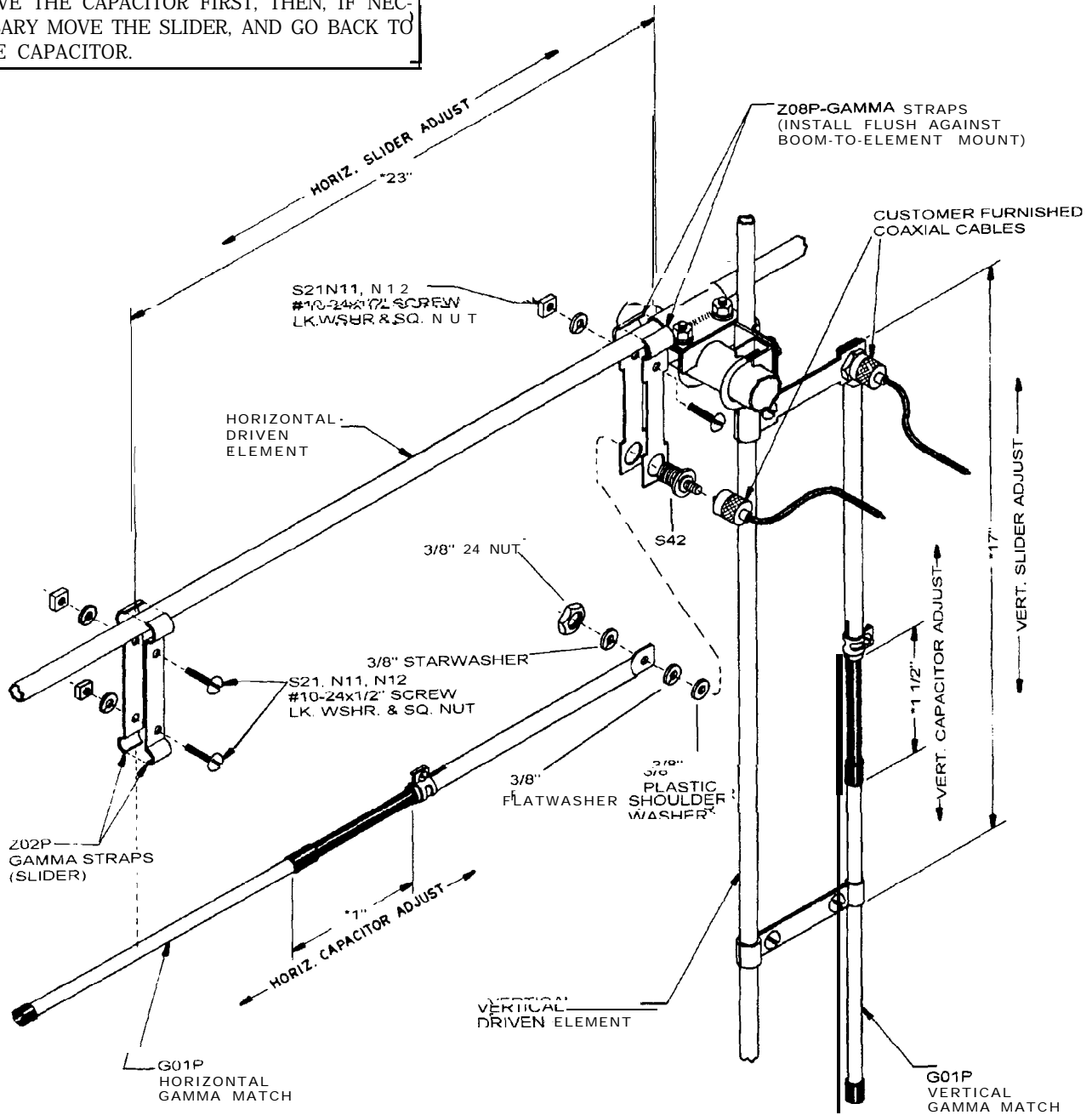

LASER 400  
GAMMA MATCH MOUNTING

FIGURE 4